

CU Series Steam Bath Generators

Installation, Operation & Maintenance Manual

Models: CU-360 through CU-4500

IMPORTANT: LEAVE THIS MANUAL WITH THE OWNER/OPERATOR

Table of Contents

Before Installing2
 Steam Room Guidelines2
 Locating the Steam Bath Generator3
 Dimensional & Clearance Specifications4
 Selecting the Steam Bath Generator5
 Installation
 Plumbing, Water Supply, Steam Line, Drain, Safety Valve . .6
 Water Quality Information6
 Steam Room Guidelines- Steam Head, Acrylic Shield7
 Electric8
 Wiring9
 Control Circuit Wiring Diagrams10-13
 F1 Plus
 Contents14
 Control Installation15
 Operating Temperature Sensor Installation16
 High Limit Operating Temperature Sensor Installation . . .16
 CU-HL Installation17
 Automatic Blowdown System
 Contents17
 Installation18
 Auxiliary Manual Reset Low Water Cutoff19
 Principles of Operation20
 Operating and Testing
 Automatic Blowdown, F1 Plus Control, CU-HL21
 Warning Signage22
 Pre-Operation Check22
 Operation
 Automatic Blowdown Instructions23
 Manual Blowdown Instructions23
 Maintenance Instructions24
 24-hour and 7-day Time Switches25
 Water Gauge & Gauge Glass Installation26
 Use and Care27
 Trouble Shooting28
 Check
 PC Boards, Probes, Steam Solenoid Valve,
 F1 Plus Control, Heating Element29
 Element Replacement Instructions30
 Typical Component Arrangement CU 360-CU 140031
 Typical Component Arrangement CU 2000-CU450032
 Replacement Parts List33-34

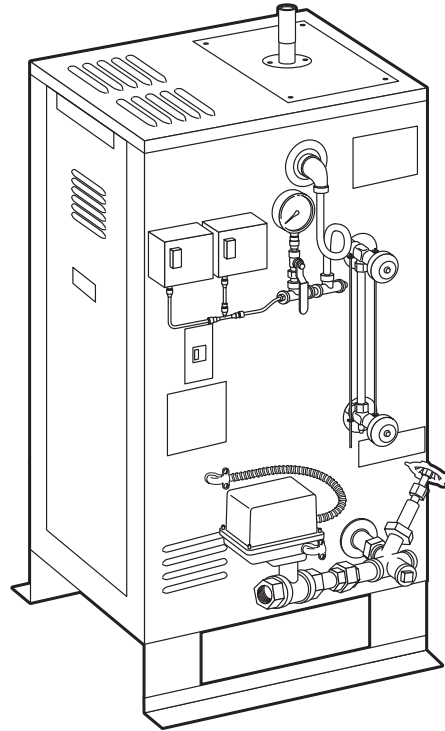

Typical CU Series Steam Bath Generator
(for illustrative purposes only)

IMPORTANT NOTE: As you follow these instructions, you will notice warning and caution symbols. This information is important for the safe and efficient installation and operation of this generator. These are types of potential hazards that may occur during this installation and operation:

CAUTION states a hazard may cause serious injury or death if precautions are not followed.

WARNING signals a situation where minor injury or product damage may occur if you do not follow instructions.

Before Installing

IMPORTANT: Take time to read these instructions thoroughly before installing or servicing. Although this CU Steambath Generator has been qualified for shipment by Mr. Steam, the following must be reviewed for proper and safe use.

1. Verify that the model and accessories are as specified and ordered.
2. Verify that the power voltage and control voltage at the site is suitable for the CU Steambath Generator.
3. Verify the correct steam generator sizing by referring to the mr.steam sizing guide. See page 5.
4. Do **NOT** use black iron pipe or galvanized pipe for the steam line. Use brass pipe or copper tubing **ONLY**, and in accordance with National and local plumbing Codes.
5. The physical size of the unit, clearance for plumbing servicing and its distance from the steam room must all be considered before selecting a location for the generator. See pages 3 & 4.
6. The Manufacturer's Data Report is supplied with the generator. This is an important document and may be required by a State or Provincial Agency. THIS DOCUMENT MUST BE SECURED IN A SAFE LOCATION.
7. Do not use or install unauthorized components, accessories or products on the generator or generator piping.

IMPORTANT: The Mr.Steam F1 Plus System operating and high limit temperature controls are to be installed in accordance with the specific instructions provided. See Note 7 below.

Steam Room Guidelines

IMPORTANT: The following general information should be used in conjunction with your architect, designer and contractor in determining all factors necessary in providing a suitable and safe steam room environment for your bathers.

IMPORTANT: Owners/operators should obtain a copy and familiarize themselves with the latest edition of the American College Sports Medicine Health/Fitness Faculty Standards and Guidelines, or a similar resource and reference publication, and refer to those guidelines for the proper and safe operation of a spa facility including steam rooms.

Steam room construction information is available from the Tile Council of America, Inc. at (864) 646-8453 or www.tileusa.com

1. Steam room must be completely enclosed, with full walls, door, floor and ceiling.
2. It is recommended that a gasketed door be used for heat sealing and steam containment. Windows, skylights and the like that are part of the steam room should be double paned. Only vapor sealed lighting fixtures approved for the application should be used.

 **CAUTION** 3. If tile or other smooth surface is used for the flooring, provide suitable anti-skid strips or equivalent, to prevent user slipping and injury.

IMPORTANT:

4. Walls and ceilings must be constructed with water-resistant, non-corrosive surface, such as tile, marble, molded acrylic, or other non-porous material. The ceiling should be sloped to prevent dripping of condensate on bathers. If acrylic, fiberglass or other non-heat resistant materials are used as part of the steam room enclosure, see page 7, "Steamhead" and "Acrylic Shield" for important additional details.
5. Provide floor drains for condensate run-off and steam room cleaning.
6. Comply with all applicable National and local building and electrical Codes and confer with design consultants and contractors for room construction details.

 **CAUTION** 7. The F1 Plus Temperature Control System is required operating equipment for each steam room. The operating temperature control is to be set by the owner/operator to sense desired room temperature at the sensor location within the steam room. Installation of the F1 Plus System high limit room temperature sensor and control is mandatory to provide additional protection to the bathers. The steam room is to be operated in accordance with "Important" information as noted above.

IMPORTANT: Final selection of the steam room temperature setting is at the discretion of the owner/operator.

Locating the Steam Generator Unit

- ! CAUTION** 1. Mr.Steam® CU commercial steambath generators are designed to NEMA Type 1 requirements and are intended for indoor use only. They are to be located indoors in a dry, clean location and are not to be subjected to moisture, condensate, hose wash down or the like.
 - ! CAUTION** 2. Do **NOT** install steambath generator outdoors or wherever environmental conditions may effect the safety and/or performance of the generator.
 - ! CAUTION** 3. Do **NOT** install steambath generator in locations such as unheated attics or basements, or where water could freeze.
 - ! CAUTION** 4. Do **NOT** install steambath generator near flammable or corrosive materials, or chemicals such as gasoline, paint thinners, or the like. Installation in areas having high concentrations of chlorine (such as pool equipment room) must be avoided.
5. **IMPORTANT:** Select a location for steam generator in accordance with items 1-4 above and within 25 feet of the steam room. Reference "Dimensional & Clearance Specifications" information on page 4. See page 5 for guidance if generator is more than 25 feet from steam room.
6. Install steambath generator on a solid and level surface, and mechanically secure generator in place.
7. Provide access to the steambath generator for servicing. See page 4 for Dimensional & Clearance Specifications
8. **IMPORTANT:** Steam line, safety valve and drain valve and plumbing, and steamheads become hot during operation and remain hot after shutdown for a period of time. Provide appropriate protection, including insulating plumbing lines. Avoid plumbing runs and steam head locations that can come in contact with service personnel and bathers. See page 6.
- ! WARNING** 9. Each steamhead must be located away from the bather seating areas and traffic patterns.

IMPORTANT: A LOCKED UTILITY ROOM THAT ONLY PERMITS ACCESS TO THE STEAM GENERATOR AND ITS CONTROLS BY AUTHORIZED PERSONNEL AND IS NOT ACCESSIBLE TO THE GENERAL PUBLIC IS STRONGLY RECOMMENDED.

Mr.Steam Installation

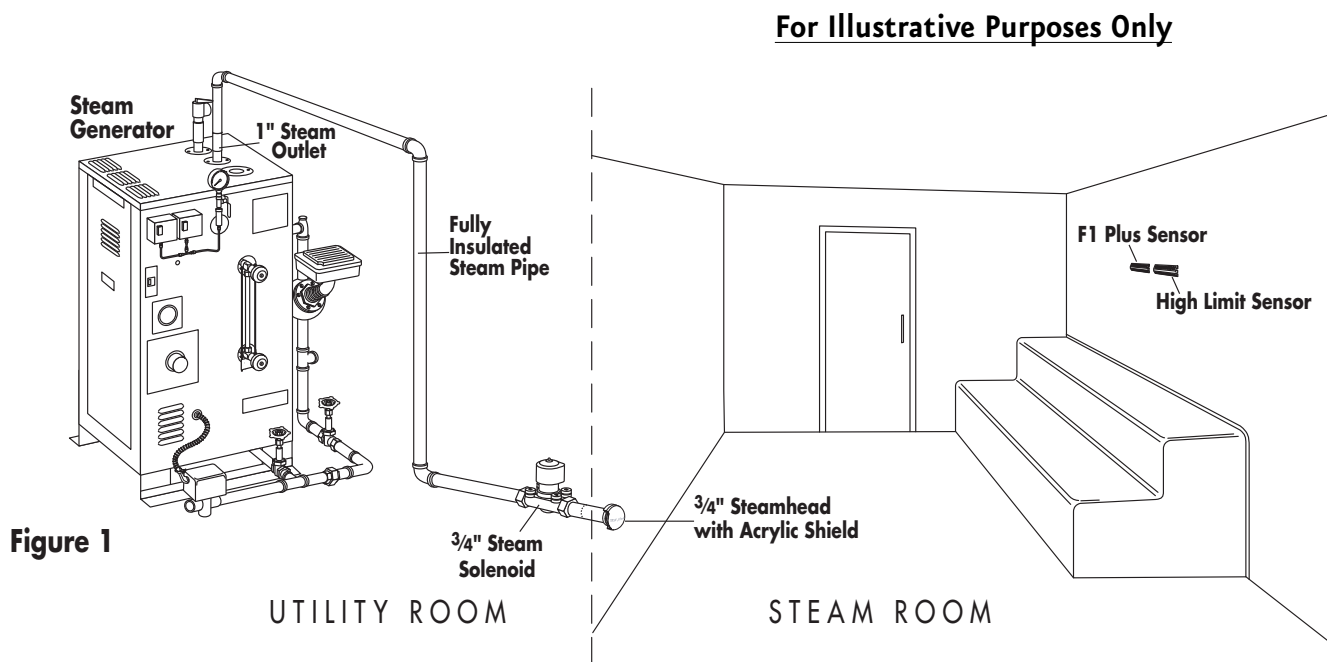

Figure 1

NOTE: FOR ILLUSTRATIVE PURPOSES ONLY. Optional equipment shown. Consult with qualified designer, architect or contractor for steam room construction details, including location of steam head(s) and sensors.

Dimensions & Clearance Specifications

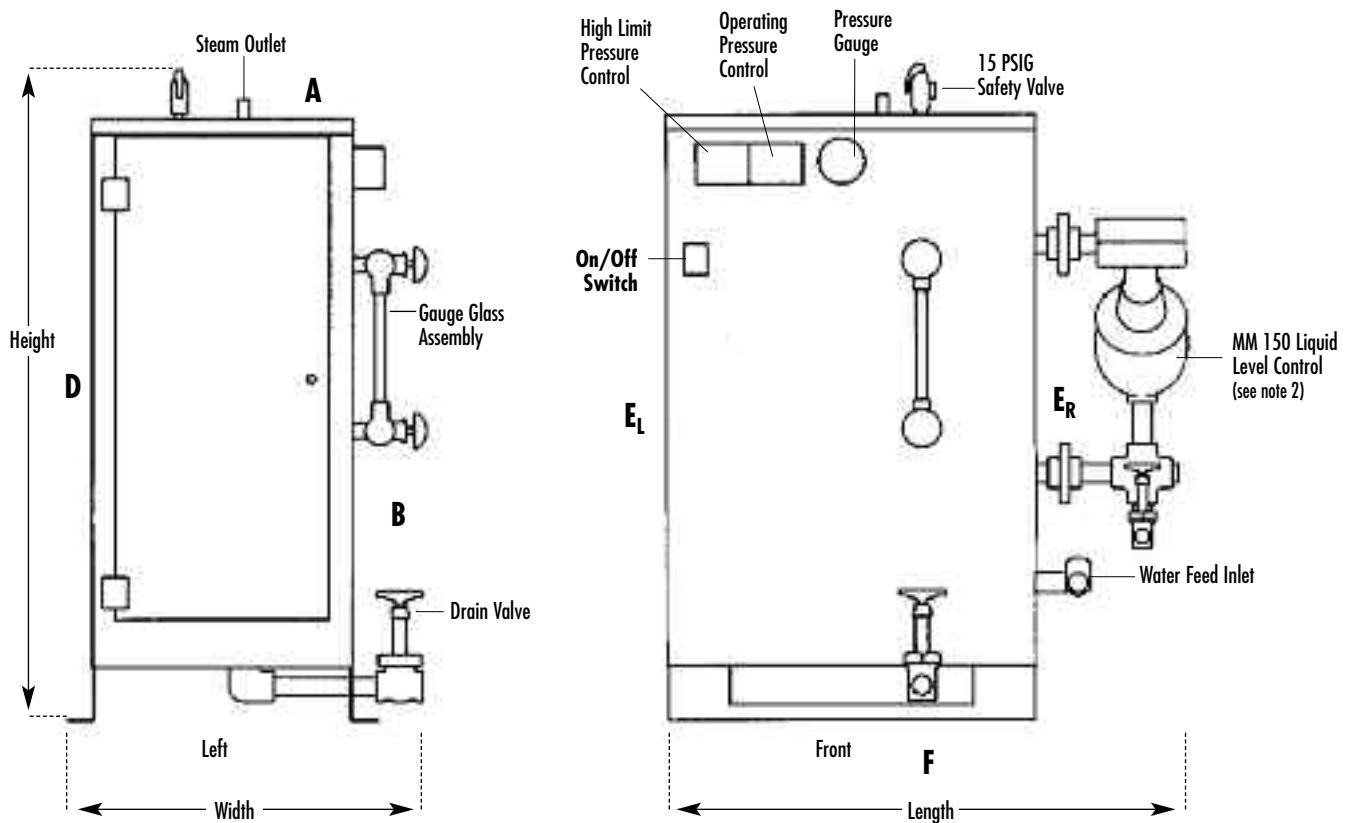

Figure 2:
 Typical Arrangement of Boiler with McDonnell Miller.
 For illustration purposes only. Refer to all notes below

NOTES for Figure 2:

1. All dimensions are approximate. Refer to chart on Page 5.
2. MM150 Liquid Level Control on CU-2000 and larger models only.
 CU-360 to CU-1400 have electronic liquid level controls.
3. **IMPORTANT: Minimum clearance from combustibile surfaces.**
 Refer to Fig. 2 above for legend.
 - A 1" above top of CU generator
 - B Front of CU generator suitable for alcove installation only.
 - D 1" from rear of CU generator.
 - E_L 1" from left side of CU generator.
 - E_R 16" from right side of CU generator.
 - F Type of flooring: "C", suitable for combustibile flooring.
4. For ease of servicing, Mr.Steam recommends a minimum of 36 inches of clearance all around the CU generator.

Select a Mr.Steam® CU Series Generator

The resultant calculated volume of the steam room determines the Model CU steambath generator required. Steam room size and additional constructional factors affect model selected.

A. To determine the steam room volume first multiply Length x Width x Height of the steam room.

Example: A steam room 8' x 9' x 8' = 576 Cu. Ft.(volume).

Select the Mr. Steam Model which is the next larger volume. In this example, Model CU-750 is the correct selection.

Example: 2 Steam rooms each 6' x 10' x 7' x 2 rooms = 840 Cu. Ft. (volume).

In this example, Model CU-1000 is the correct selection.

SEE NOTE B BELOW

NOTE: Insure adequate consideration is given to assure that the CU unit selected is not undersized for the room.

B. NOTE: Certain additional factors effect the correct sizing of the steambath generator:

1. Construction materials such as glass or glass block, natural marble or other stones: Increase volume.
2. Piping runs longer than 25 feet from the steambath generator to the steam room: Increase volume.
3. Exterior walls and outside windows: Increase volume.
4. Steam room with interior height in excess of 8 feet: Increase volume

C. IMPORTANT:The above selection guidelines are recommendations only. Always consult with contractor, designer or architect. For general information, contact East Coast: 1-800-767-8326 or West Coast: 1-800-727-8326.

D. IMPORTANT: When specifying a CU Commercial Steambath generator the following is strongly recommended for best performance and user satisfaction.

1. One CU steambath generator should service no more that two (2) steam rooms, each relatively similar in size and construction.
2. If two (2) steam rooms are serviced by one (1) CU generator, the combined resultant room volume of the two rooms should not exceed 1000 cubic feet.
3. Each room must be operated with the appropriate F1 Plus temperature control system inclusive of the room operating temperature control and the high-limit temperature control.
4. In any case, the purchase and/or owner/operator must consult with a designer, architect, and/or consultant to assure the proper specification of the steam generator.

Model No.	KW	Maximum* Room Volume (cu ft)	Water Inlet Size NPT	Steam Generator Outlet Size, NPT	Dimensions (inches)			Shipping Wt. lbs.
					Width	Length	Height	
CU-360	9	400	3/8"	1"	20	30	38	250
CU-500	12	500	3/8"	1"	20	30	38	250
CU-750	18	750	3/8"	1"	20	30	38	250
CU-1000	24	1000	3/8"	1"	20	30	38	270
CU-1250	30	1250	3/8"	1"	20	30	38	290
CU-1400	36	1400	3/8"	1"	20	30	38	300
CU-2000	48	2000	1/2"	1"	24	33	44	330
CU-2500	60	2500	1/2"	1"	24	33	44	380
CU-3000	72	3000	1/2"	1"	24	33	44	390
CU-4500	108	4500	1/2"	1-1/2"	28	34	59	625

*After taking into consideration all factors affecting resultant steam room volume, including materials of construction, distance from generator to steam room, interior height of steam room ceiling, outside/exterior walls and windows etc., select proper Model CU generator. Consult with architect, designer and contractor before making final selection.

Installation

Plumbing

All plumbing shall be performed by a qualified licensed plumber and in accordance with applicable National and local Codes.

Water Supply

1. Connect to hot or cold water line. A hot water line is preferable, however incoming hot water should not exceed 160°F

IMPORTANT: The low temperature setting on many hot water heaters provides 120°F water

2. Provide a service shut off valve and water-line strainer in the water supply line upstream to the steambath generator
3. Flush the inlet water line thoroughly before making connection to the steambath generator.
4. Incoming water supply should be at least 25 psig and is not to exceed 100 psig.
5. Install a back flow preventor as required by Code.
6. Provide anti-water hammer device as required in accordance with Code.
7. Use of unions in plumbing lines is strongly recommended.
8. Recheck all factory and field plumbing connections for tightness.

Steam Line

1. The F1 Plus steam solenoid valve should be plumbed as close as practical to the steam room using only brass pipe or copper tubing.
2. Pitch the steam line a minimum of 1/4" per linear foot of run, towards the steam outlet on the generator, avoid valleys and trapping of condensate.
3. Fully insulate steam lines with suitably-rated high temperature insulation.
4. Install a suitable strainer or filter between the steam generator and steam solenoid valve.
5. Use of unions in plumbing lines is recommended.

Drain

In accordance with Code requirements, provide a drain line connection from the steambath generator drain valve(s). If an Auto Blowdown is used, the drain line must be connected to the automatic blowdown valve. Refer to National and local plumbing Codes for drain requirements including receptor, trap, vent requirements and drain lines.

Safety Valve

Where permitted by Code, provide a connection for safety valve discharge.



WARNING

DO NOT connect a shut off valve or plug at the safety valve outlet.
DO NOT reduce outlet size of safety valve discharge.

PIPE SIZE GUIDE

Steam Outlet:	1"
Steam Solenoid Valve:	3/4"
Steam Head:	3/4"

Water Quality Information

For optimum results, the feedwater supply should be tested prior to initial startup. If the mineral content exceeds the following recommended limits, various external treatment processes may be used to correct the problem.

NOTE: An analysis of the on-site boiler feedwater must be made by a recognized and reliable water treatment company to ascertain the existing condition and treatment required.

Recommended Feedwater Quality

Hardness, ppm	8 – 85 (~0.5 – 5 gpg)
P-Alkalinity, ppm	85 – 410 (~5 – 24 gpg)
T.Alkalinity, ppm	200 – 500 (~7 – 0 gpg)
pH (strength of alkalinity)	8.0 – 11.4

Blowdown boiler at least a once a day.

If boiler water or feed-water are outside the above limits, a more frequent blowdown is required

Recommended Limits Within a Boiler

Total Dissolved Solids, ppm	3500	Sulfite (SO ₃), ppm	25 – 50
Total Alkalinity, ppm	850	Phosphate, ppm	30 – 60
Suspended solids, ppm	300	P-Alkalinity as CaCO ₃ , ppm	900
Silica (SiO ₂), ppm	125	Iron, ppm	2

Water quality can affect efficiency or result in boiler damage if neglected. Boiler feedwater contains impurities in solution and suspension. These impurities concentrate in the boiler. The concentration of these impurities increases as more feedwater is introduced into the boiler and steam is produced. If the suspended solids are allowed to concentrate beyond certain limits, a deposit or "scale" will form on the boiler internal surfaces. This deposit can interfere with the proper boiler operation and cause boiler failure.

The concentration of these impurities is generally controlled by the feed-water quality and by blowdown. Blowdown refers to removing a portion of the boiler water with high solids concentration and replacing it with makeup water of a lower concentration.

Steam Room Guidelines

IMPORTANT: The following general information should be used in conjunction with your architect, designer and contractor in determining all factors necessary in providing a suitable and safe steam room environment for your bathers.

IMPORTANT: Owners/operators should obtain a copy and familiarize themselves with the latest edition of the American College of Sports Medicine Health/Fitness Faculty Standards and Guidelines (ISBN: 0736051538), or a similar resource and reference publication, and refer to those guidelines for the proper and safe operation of a spa facility including steam rooms.

Steamhead (3/4" N.P.T.)

1. For steam rooms constructed of tile, marble or similar non-porous heat-resistant materials for the enclosure, locate steam head 12 inches above steam room floor and install Mr.Steam PN CU-103412 acrylic shield on each steamhead.

IMPORTANT: For Steam rooms using acrylic, fiberglass or other non-heat resistant materials used for steam room enclosure, install each steam head 20-30 inches above the floor.

2. Locate each steamhead away from bather seating area and away from traffic patterns.
3. Install each steamhead with steam slots facing to the left and right as shown in the diagrams.
4. **NOTE:** To preserve the steamhead finish, do not use wrench or other tools to tighten. Use of proper thread sealant and hand tightening is usually sufficient.
5. Apply a bead of silicone around the steamhead where it meets the wall.

Acrylic Shield

Apply a small bead of silicone in the grooves on the top and bottom of the steamhead. Place an Acrylic Shield (PN 103985) over the steamhead until the tabs engage the grooves in the steamhead.

! WARNING Operation of the steam room without an acrylic shield may expose users or surfaces to hot steam. Do not operate steam room without an acrylic shield on each steamhead.

IMPORTANT: Do not use with water soluble fragrance or fragrance containing emulsifiers or aldehydes. Acrylic Shield damage may result. Mr.Steam oils are approved for use with this acrylic shield.

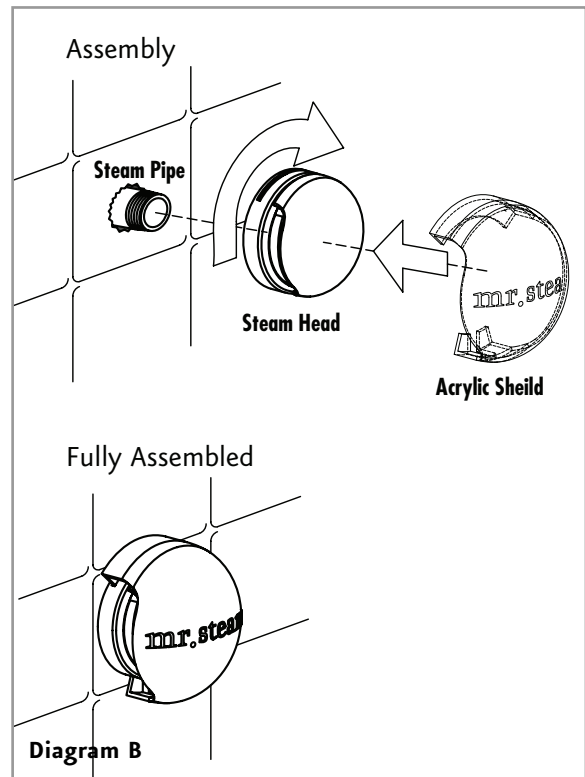
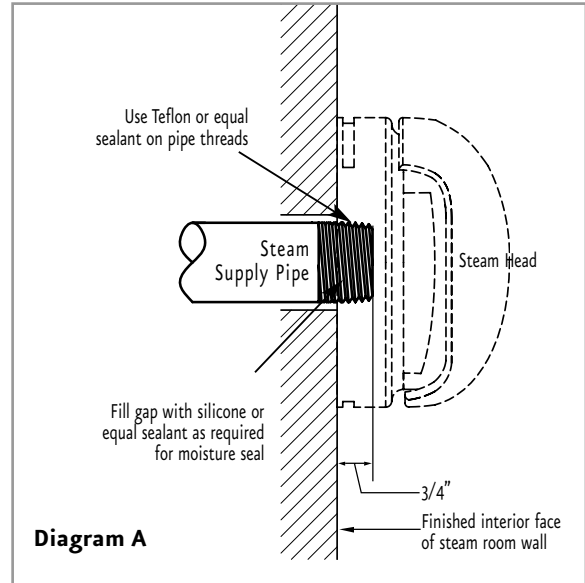

Electric

! WARNING Electric shock hazard. Disconnect all power supplies at the main disconnect switch before proceeding. All electrical wiring must be installed by a qualified licensed electrician in accordance with National and local Codes.

The steambath generator is factory wired and pre-tested before shipment. Electrical power supply details are provided on the data plate secured to the generator and as part of this manual. Refer to applicable wiring and schematic information.

1. Check power and control circuit voltage requirements on the data plate.

NOTE: Separate 120 VAC line is not required if optional 120 VAC control transformer has been purchased and provided as factory equipment.

2. Use minimum 90° C insulated copper conductors only for field wiring, sized in accordance with National and local electric Codes. Refer to Amperage Chart below.

3. Connect suitably sized copper equipment grounding conductor in accordance with National and local electric Codes to ground terminal provided.

4. Install a separate dedicated circuit breaker or other approved overcurrent protection device between the incoming electrical supply and the generator, in accordance with National and local electric Codes.

5. **IMPORTANT:** With main disconnect switch off and no electric power entering the generator, tighten all electrical connections including all factory connections at the terminal block, fuse block, top and bottom of contactor and element pins prior to energizing generator (torque values are listed on individual components, control circuit terminal strips should be torqued to 20 in-lbs.).

AMPERAGE CHART - Indicates Total Ampere Draw of Specific CU Model at Voltage & Phase Specified

Model No.	kW	208V/1 PH	208V/3 PH	240V/1 PH	240V/3 PH	480V/3 PH	600V/3 PH
CU-360	9	44	25	38	22	11	9
CU-500	12	58	34	50	29	15	12
CU-750	18	87	50	75	44	22	18
CU-1000	24	116	67	100	58	29	24
CU-1250	30	145	84	125	73	37	29
CU-1400	36	-	100	-	87	44	35
CU-2000	48	-	134	-	116	58	47
CU-2500	60	-	167	-	145	73	58
CU-3000	72	-	200	-	174	87	70
CU-4500	108	-	300	-	260	130	104

IMPORTANT: Use minimum 90° C insulated copper conductors only for field wiring sized in accordance with National and local electric Codes.

NOTE: Consult factory for other voltage/phase combinations. CU generators are suitable for 50/60 hz. Standard control circuit voltage for above V/PH combinations for United States, Canada and Mexico is 120 VAC. Exception: 220-240 VAC control circuit voltage is provided on non-domestic product where power voltage is 220-240 V/3 PH, 380V/3PH, 415V/3 PH, etc.

Wiring

CAUTION To avoid possible electric shock, the steambath generator shall be suitably grounded in accordance with National Electric and local Codes. Disconnect all power supplies at the main disconnect switch before proceeding.

1. Electric wiring to the steambath generator must be in accordance with National Electrical and local wiring Codes following wiring diagram supplied. Such wiring shall be done by a licensed electrician. See Amperage Chart and Notes, Page 8.
2. The unit is wired and pre-tested before shipment. Follow all instructions provided for safely and properly wiring steambath generator and accessories.

CAUTION Installer shall use a safety switch of adequate capacity employing suitably rated circuit breakers or fuses between main electrical power source(s) and the generator. Location of safety switch to be in accordance with National and local electric codes.

3. **IMPORTANT:** Insure all electrical connections are sufficiently tightened prior to energizing generator. See Page 8, Item 5.

WARNING Substitution of components or modification of wiring systems voids warranty and can lead to dangerous operating conditions.

4. The F1 Plus Temperature Sensor and High Limit Temperature sensor(s) must be located inside the steam room. Locate approximately 5 feet above the steam room floor, preferably away from steam heads.
5. The F1 Plus steam solenoid valve(s) shall be located outside the steam room and shall be wired to the F1 Plus controller(s) in accordance with wiring diagram provided. See applicable wiring diagrams included as part of this manual.

CAUTION Do not cut or splice the sensor cable. If the sensor cable is not long enough then relocate the F1 Plus control to a secure location. Cutting or splicing the sensor cable may adversely affect sensor operation.

Typical Power Wiring Diagram

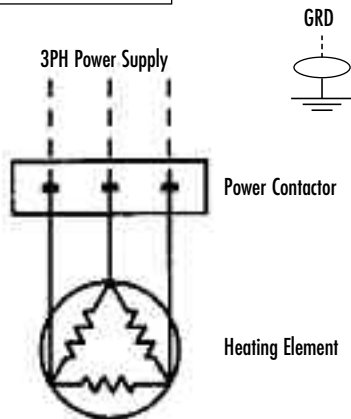
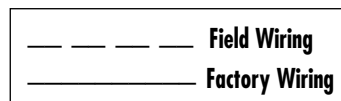

Diagram #1
Units with 1 Contactor (see note 1)

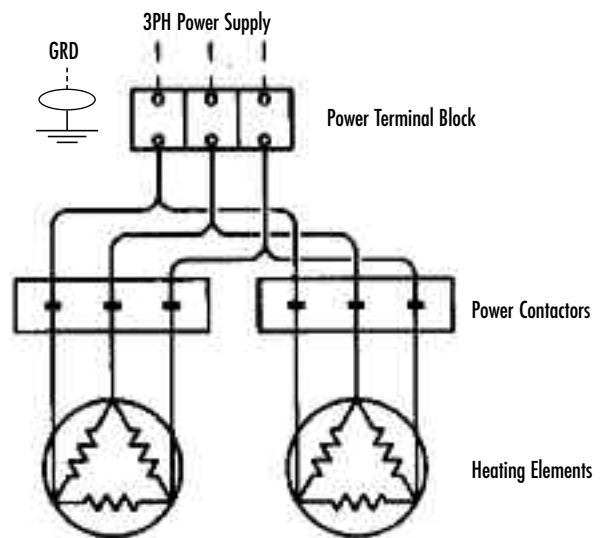

Diagram #2
Units with 2 or more Contactors (see note 1)

IMPORTANT: Also refer to Control Circuit diagrams in this manual.

Control Circuit Wiring Diagram

SEE PAGES 11, 12 & 13 FOR DIAGRAMS

NOTES:

1. Larger rooms may require two or more steam solenoid valves in parallel.
2. When generator services two rooms, second room requires a set of F1 Plus solenoid valves and CU-HL.

IMPORTANT:

3. F1 Plus sensors are intended to be field installed within the steam room at the location selected by the designer/architect. DO NOT LOCATE THE F1 PLUS SENSORS NEAR OR ABOVE THE STEAMHEAD(S) AS THIS MAY CAUSE DIRECT STEAM EMISSION TO INTERFERE WITH STEAMROOM TEMPERATURE REGULATION.
4. Autoflush System 24 hr. timer and F1 Plus operating settings are at the discretion of the owner/operator.

IMPORTANT: Owners/operators should obtain a copy and familiarize themselves with the latest edition of the American College Sports Medicine Health/Fitness Faculty Standards and Guidelines, or a similar resource and reference publication, and refer to those guide lines for the proper and safe operation of a spa facility including steam rooms. Steam room construction information is available from the Tile Council of America, Inc. at (864) 646-8453 or www.tileusa.com.

 **WARNING** The F1 Plus Temperature Control System is required operating equipment for each steam room. The operating temperature control is to be set by the owner/operator to sense desired room temperature at the sensor location within the steam room. Installation of the F1 Plus System high limit room temperature sensor and control is mandatory to provide additional protection to the bathers. The steam room is to be operated in accordance with “Important” information as noted above.

IMPORTANT: Final selection of the steam room temperature setting is at the discretion of the owner/operator.

 **WARNING** Do not cut or splice the sensor cable. If the sensor cable is not long enough then relocate the F1 Plus control to a secure location. Cutting or splicing the sensor cable may adversely affect sensor operation.

Control Circuit Wiring Diagram

F1 Plus Temperature Control System and optional automatic blowdown assembly
For Models: CU-360A to CU-750A and CU-1000AF3, CU-1250AF3, CU-1400AF3

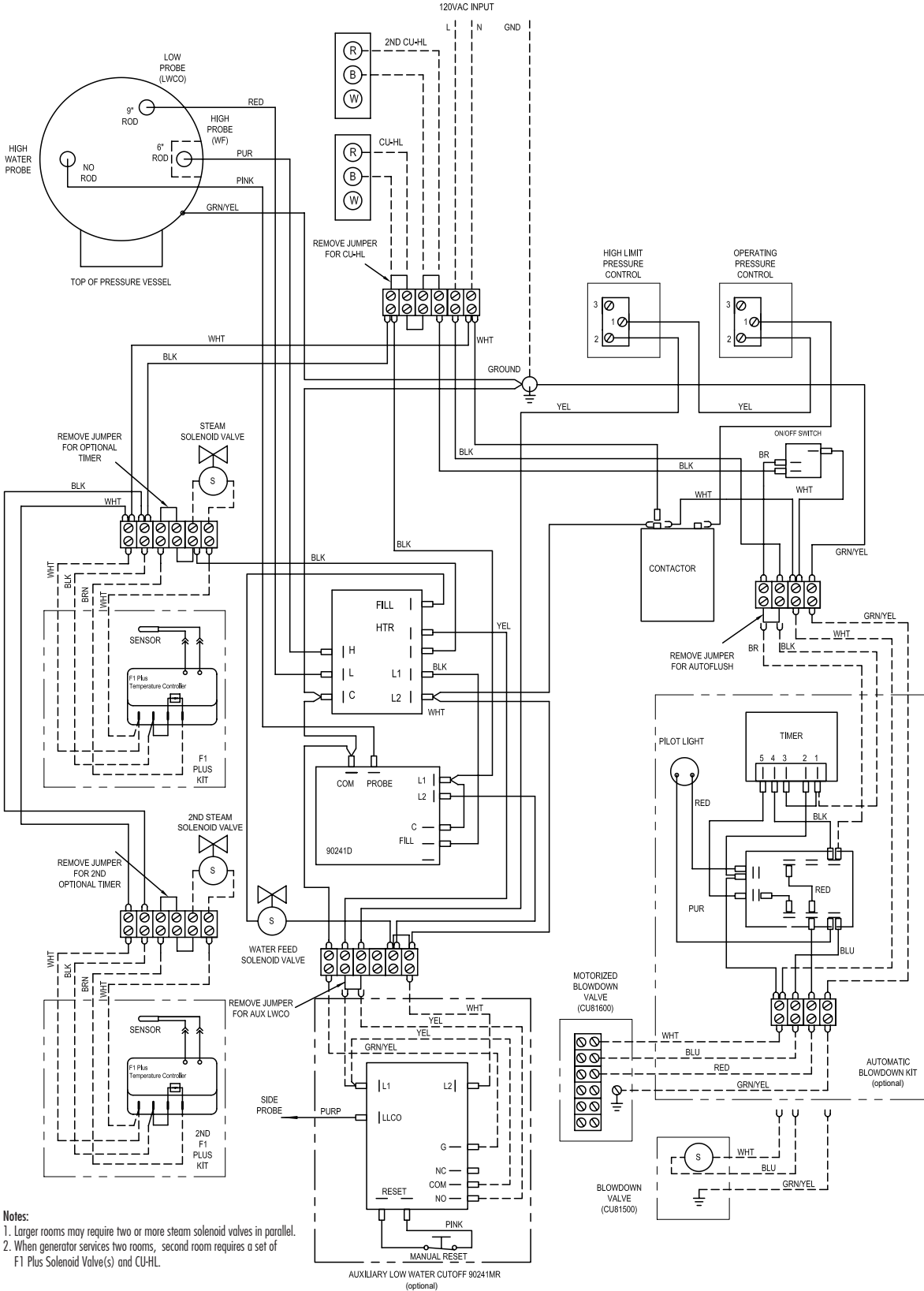

- Notes:**
1. Larger rooms may require two or more steam solenoid valves in parallel.
 2. When generator services two rooms, second room requires a set of F1 Plus Solenoid Valve(s) and CU-HL.

Control Circuit Wiring Diagram

F1 Plus Temperature Control System and optional automatic blowdown assembly

For Models: CU-1000AB3, CU-1000AC3, CU-1250AB3, CU-1250AC3, CU-1400AB3, CU-1400AC3

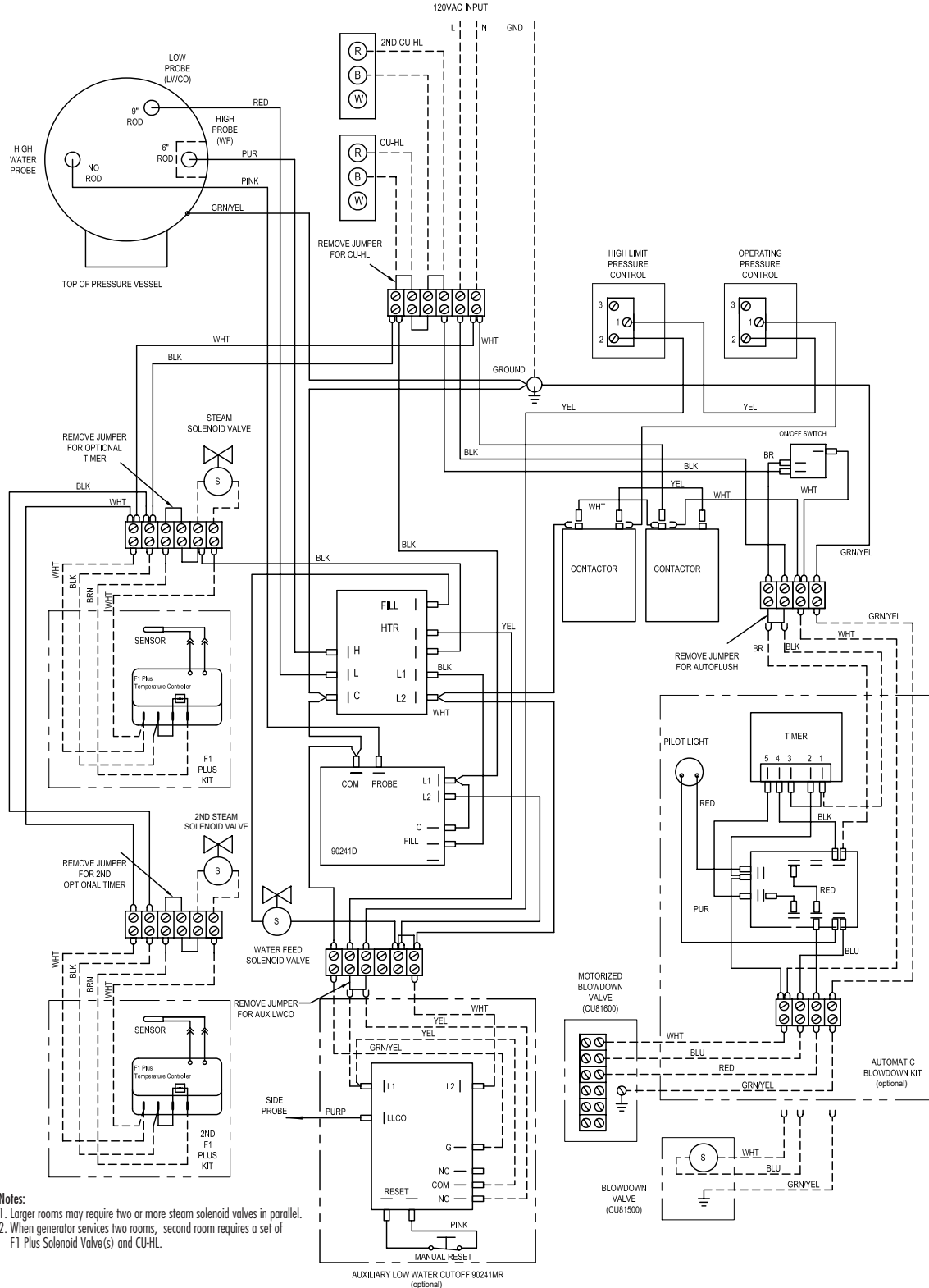

Notes:

1. Larger rooms may require two or more steam solenoid valves in parallel.
2. When generator services two rooms, second room requires a set of F1 Plus Solenoid Valve(s) and CU-HL.

Control Circuit Wiring Diagram

Models CU-2000 and higher with F1 Plus Temperature Control System and Optional Automatic Blowdown Assembly

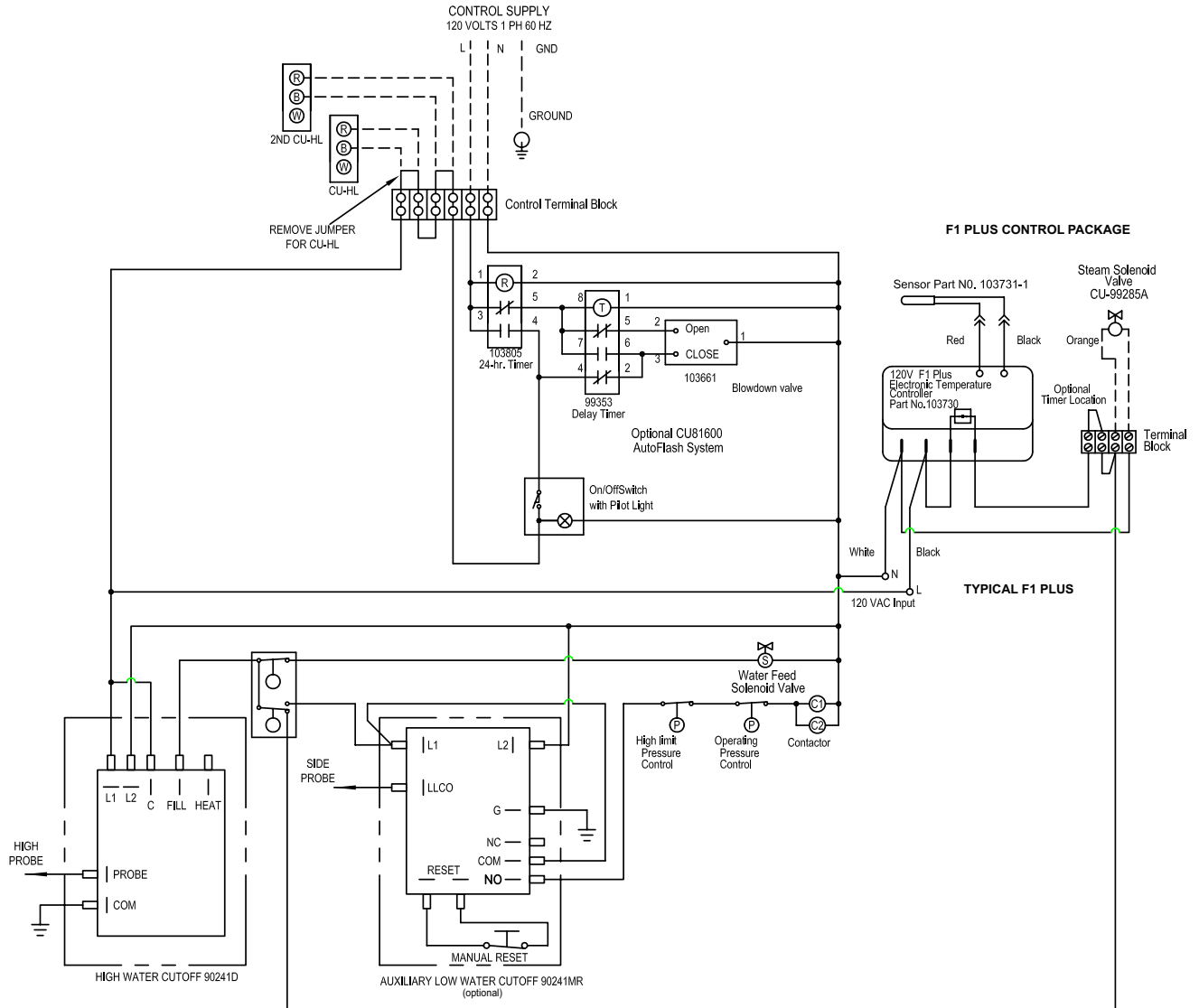

IMPORTANT:

1. F1 Plus sensors are intended to be field installed within the steam room at the location selected by the designer/architect. DO NOT LOCATE THE F1 PLUS SENSORS NEAR OR ABOVE THE STEAMHEAD(S) AS THIS MAY CAUSE DIRECT STEAM EMISSION TO INTERFERE WITH STEAMROOM TEMPERATURE REGULATION.

2. Autoflush System 24 hr. timer and F1 Plus operating settings are at the discretion of the owner/operator.

IMPORTANT: Owners/operators should obtain a copy and familiarize themselves with the latest edition of the instruction manual.

F1 Plus® Kit Contents

Mr.Steam CU Steambath Generator can be used for one or two steam rooms in accordance with Page 5, Item D. Each room requires one F1Plus Kit sized for the room. See page 3 (figure 1) for typical installation.

F1 PLUS KIT CONSISTS OF:

- F1 Plus Control (factory installed on generator)
- F1 Plus Sensor
- CU-HL Room High Temperature Limit Control
- One 3/4" Steam Solenoid Valves and 3/4" Steamhead
- Acrylic Shield
- Sensor Covers

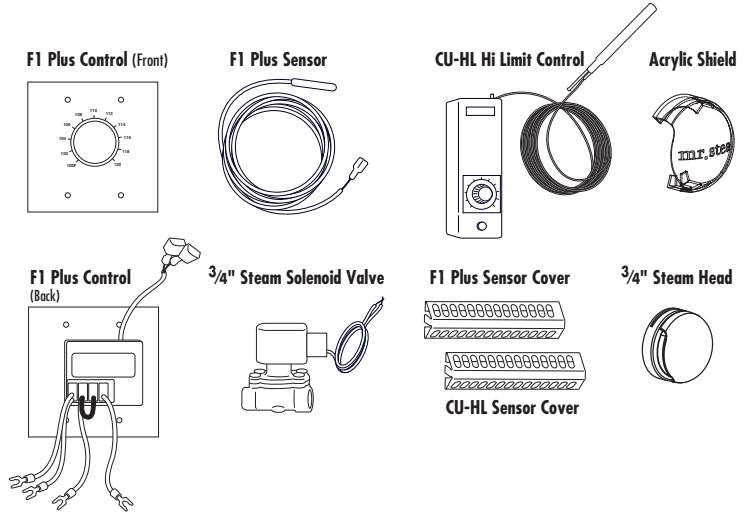

CU2-F1 Plus® Kit Contents

CU 2000–4500 serving one room using two steam solenoid valves and two steamheads.

CU2-F1PLUS KIT CONSISTS OF:

- F1 Plus Control (factory installed on generator)
- F1 Plus Sensor
- CU-HL Room High Temperature Limit Control
- Two 3/4" Steam Solenoid Valves and 3/4" Steamhead
- Two Acrylic Shields, one for each steamhead
- Sensor Covers

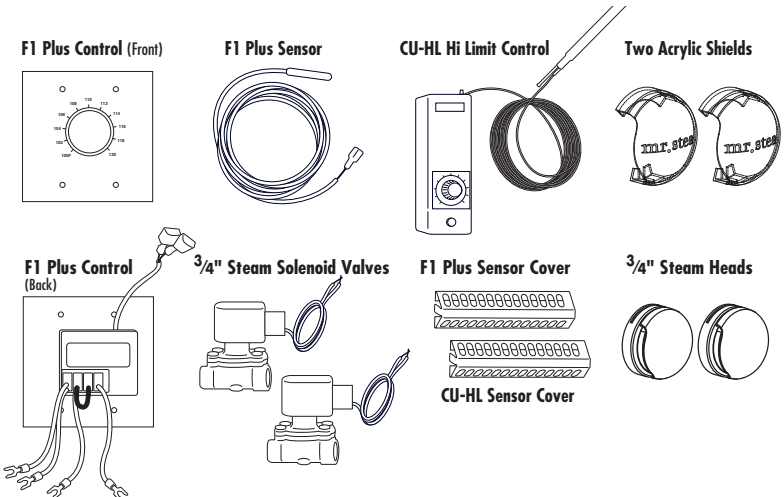

CU2-F1 Plus® Typical Installation

(CU2000-4500 serving one room using two steam solenoid valves and two steamheads)

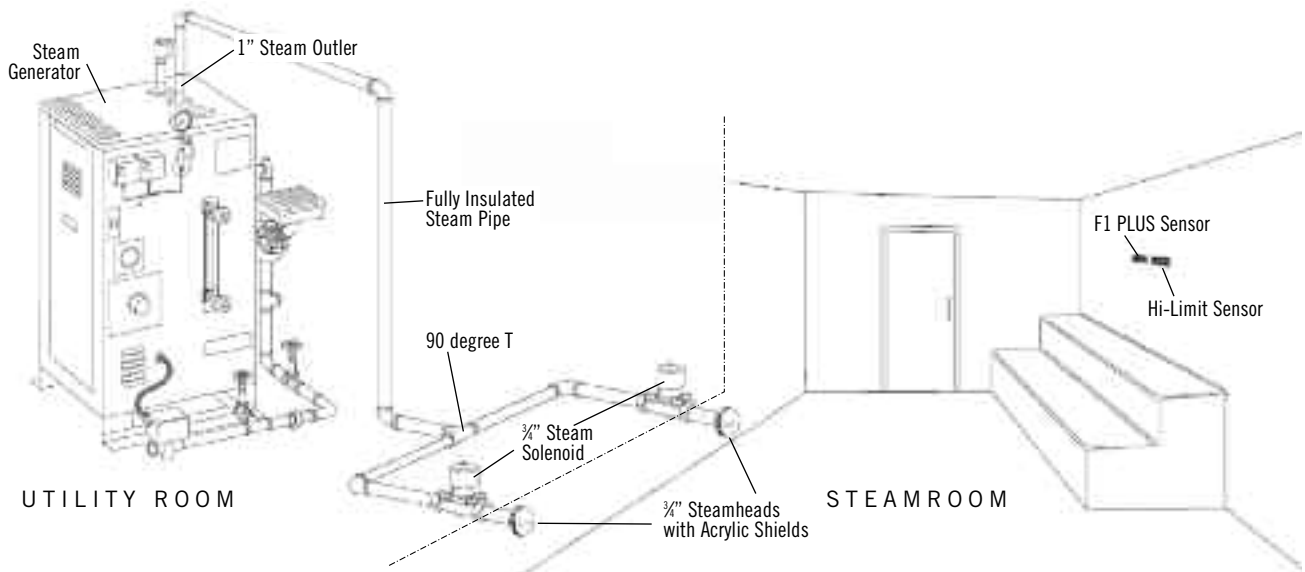

NOTE: FOR ILLUSTRATIVE PURPOSES ONLY. Optional equipment shown.

Consult with qualified designer, architect or contractor for steam room construction details, including location of steam head(s) and sensors.

F1 Plus® Control Installation

NOTE: If the steam generator came with a factory installed F1 Plus control skip to page 16.

! WARNING Hazard of Electric Shock. Disconnect all power supplies before making wiring connections.

NOTE: Reference applicable wiring diagram.

1. Remove 4" diameter blank cover located on steam generator. Mount the F1 Plus faceplate on the back of the generator cabinet with provided screws and nuts. For one room installation use the upper blank.
2. Connect the control wires to the bottom of the terminal block above the control. The terminals are coded with the wire insulation color: White-Black-Brown-skip-skip-White.
3. Refer to applicable schematic for proper wire connections.

Control Panel Showing One F1 Plus Control

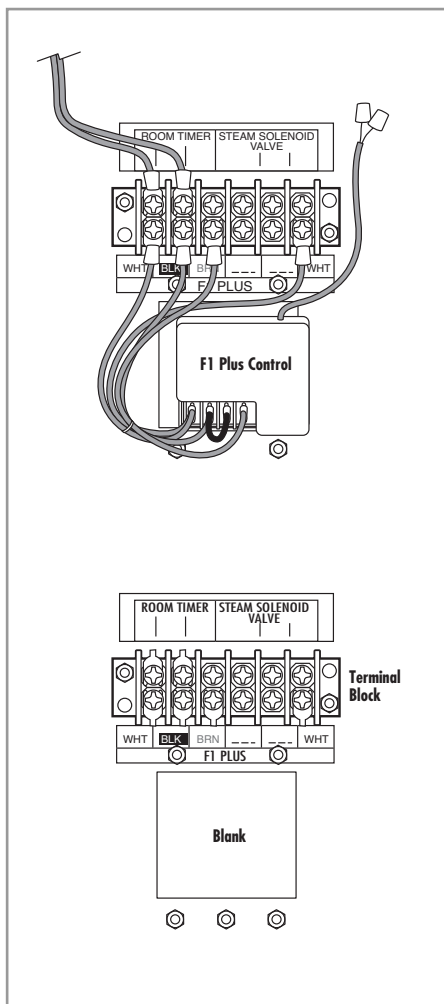

Control Panel Showing Two F1 Plus Controls

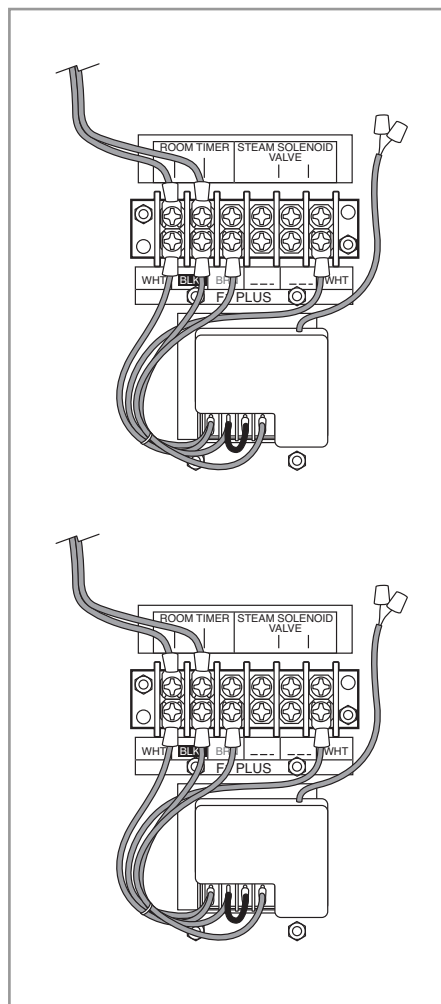

F1Plus® Operating Temperature Sensor Installation

- Locate sensor on a wall inside the steam room five (5) feet above the floor.

DO NOT LOCATE THE F1 PLUS SENSORS NEAR OR ABOVE THE STEAMHEAD(S) AS THIS MAY CAUSE DIRECT STEAM EMISSION TO INTERFERE WITH STEAMROOM TEMPERATURE REGULATION.

- Route sensor cable directly to F1 Plus Control.
- Do not splice the sensor cable.
- Do not route sensor cable inside metal conduit.
- Do not route sensor cable with power wiring, next to electric motors or any other location subject to electrical noise.
- Seal cable entrance to steam room with silicone.
- Protect sensor with bulb guard provided.

CAUTION Do not cut or splice the sensor cable. If the sensor cable is not long enough then relocate the F1 Plus control to a secure location. Cutting or splicing the sensor cable may adversely affect sensor operation.

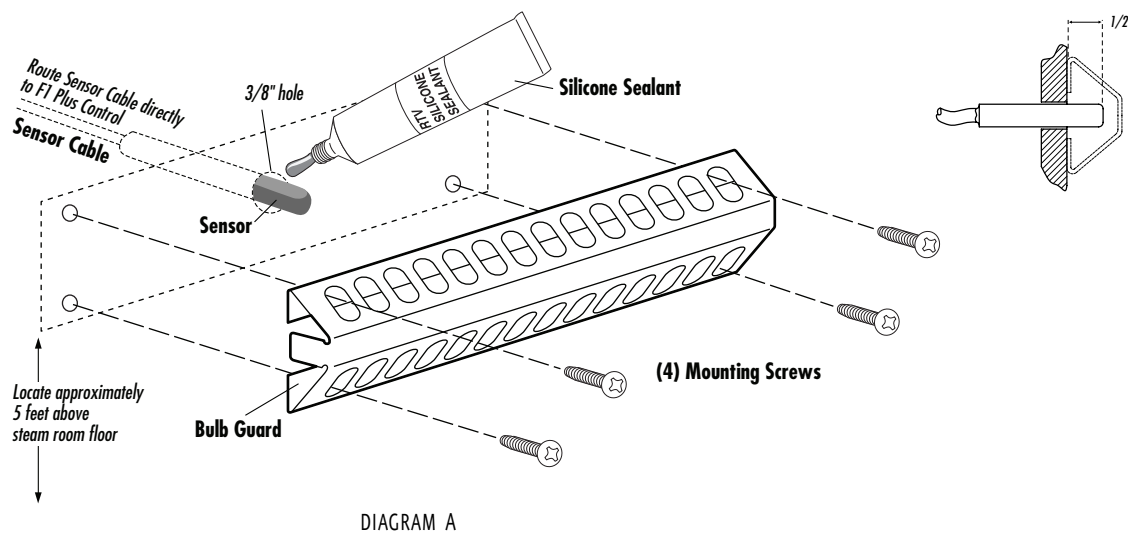

CU-HL High Limit Operating Temperature Sensor Installation

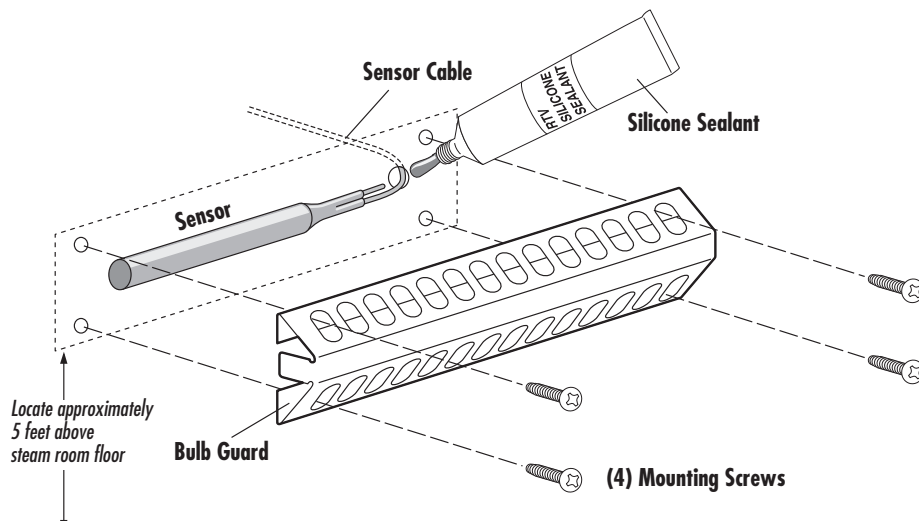

CU-HL Installation

NOTE: Reference applicable wiring diagram, pgs. 11, 12 & 13.

1. Model CU-HL room temperature control unit must be installed outside the steam room. Consider the length of capillary (20 ft) before mounting.
2. Sensing bulb must be installed inside the steam room five (5) feet above the floor on a wall. It is recommended that it not be located directly by above the steamhead. **DO NOT LOCATE THE CU-HL SENSORS NEAR OR ABOVE THE STEAMHEAD(S) AS THIS MAY CAUSE DIRECT STEAM EMISSION TO INTERFERE WITH STEAM-ROOM TEMPERATURE REGULATION.**
3. Remove screw above the dial and remove cover.
4. Mount housing using mounting holes at the back of the control. Locate CU-HL where it is accessible to authorized personnel only. It is not to be accessible to the general public.

! WARNING To Avoid Electric Shock. Do not install control unit inside steam room or in any wet or damp location.

5. Install sensing bulb **INSIDE** steam room five (5) feet above the floor on a wall. Avoid sharp bends or kinks in capillary tubing. This could affect the controller's performance and may result in unsafe operation. Excess capillary should be very carefully coiled and placed beneath the control unit.

6. Secure sensing bulb to the wall with the sensor bulb guard provided (see page 16, Diagram B).

! WARNING Hazard of Electric Shock. Disconnect all power supplies before making wiring connections.

7. Connect wiring to CU steambath generator. See applicable wiring diagram. Remove jumper next to 120v control supply input of CU generator. Using AWG #14 or larger wire, connect terminals R and B of controller to the terminals vacated by the jumper. Also connect ground wire from controller ground terminal to CU ground terminal.

NOTE: All factory ground wiring is color coded using green/yellow insulation.

8. Set differential dial to maximum, "12".
9. Reassemble cover and screw.
10. Set the thermostat knob of Model CU-HL to max 130° F or at the maximum temperature permitted by jurisdiction.

Automatic Blowdown System

CU 81600

The Automatic Blowdown System consists of the following factory installed items:

- Blowdown Control Panel
- Motorized Drain Valve Assembly #CU-81600

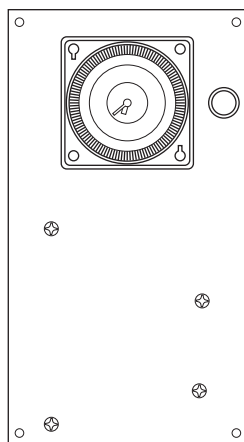

Front

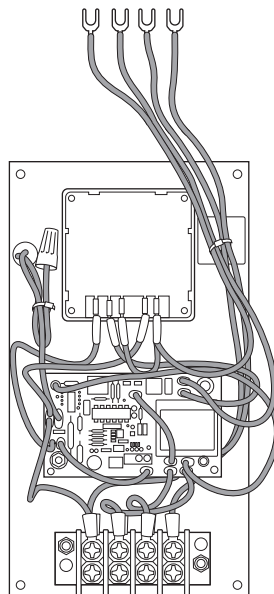

Back

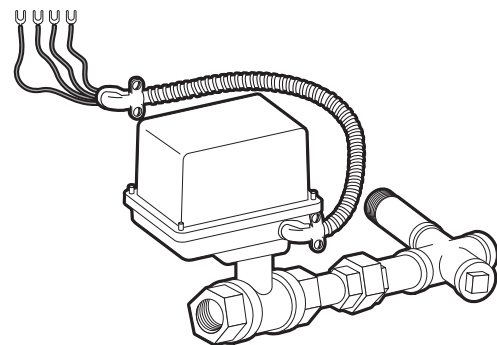

**CU-81600
Motorized Drain Valve**

Automatic Blowdown System Kit Installation

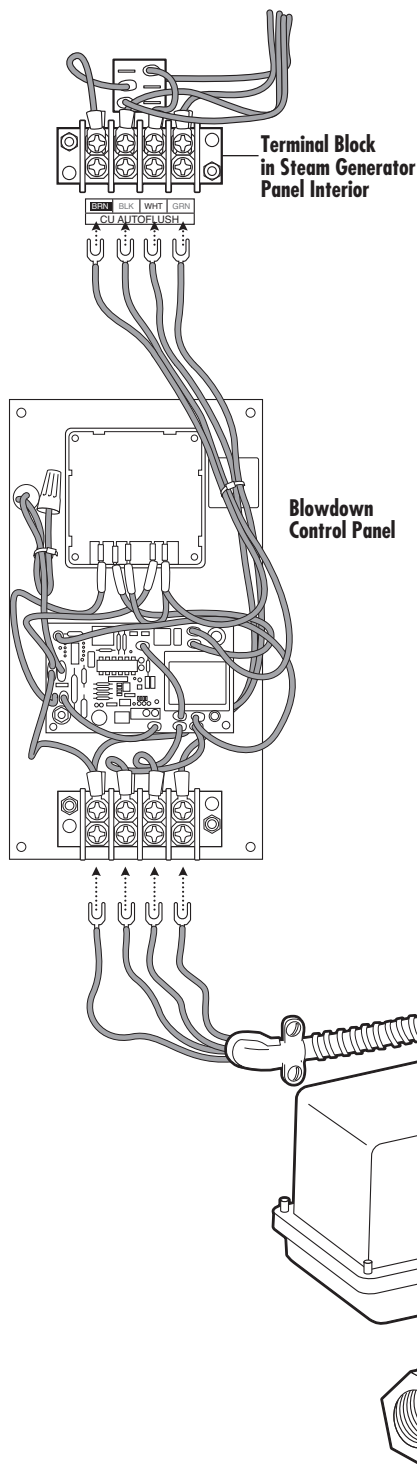

CU-81600 Motorized Drain Valve Assembly

Note: If the steam generator came with a factory installed Automatic Blowdown System see page 25 on how to program the timer.

! WARNING Hazard of Electric Shock. Disconnect all power supplies before making wiring connections.

Note: Reference applicable wiring diagram.

1. Remove blank cover and mount the Automatic Blowdown Control Panel on the front of the generator cabinet with screws and nuts provided.
2. Remove the jumper between Brown and Black from the terminal block above the panel.
3. Connect the wires to the terminal block. The terminals are coded with the wire insulation color: Brown-Black-White-Green.
4. Plumb the motorized valve assembly to the generator drain valve.
5. Install the valve cable in the knockout below the Automatic Blowdown Control Panel.
6. Connect the wires to the terminal block at the bottom of the panel. The terminals are coded with the wire insulation color. CU81600: White-Blue-Red-Green
7. Program the timer and set the clock (See page 25)

Auxiliary Manual Reset Low Water Cutoff

! WARNING Hazard of Electric Shock. Disconnect all power supplies before making wiring connections. Make sure boiler is not hot and has no pressure and is drained.

NOTE: Reference applicable wiring diagram.

1. Install the auxiliary low water cutoff pc board below the AUX LWCO terminal block inside the control panel using screws provided.
2. Remove jumper between Yellow and Yellow from terminal block.
3. Connect the pc board wires to the terminal block.
The terminals are coded with the wire insulation color: Green-Yellow-Yellow-Black-White-none.
4. Install manual reset button and connect wires to RESET terminals on pc board.
5. Locate and punch out knockout on middle and back of generator.
6. Remove the cover from the back of the generator to expose the 3/8" plug. The cover can be discarded.
7. Remove the 3/8" NPT plug and install the side probe using Teflon tape or dope on the threads.
8. Put the electrical junction box over the probe, with the cover side facing out. Using the holes in the back of the new electrical junction box as a template drill two 0.147 diameter (#26 drill) holes in the sheet metal jacket of the generator.
9. Secure the junction box to the jacket with two #8 sheet metal screws.
10. Install other end of the probe cable in the knockout adjacent to AUX LWCO pc board.
11. Connect probe wire to LLCO terminal on Aux Lwco pc board.

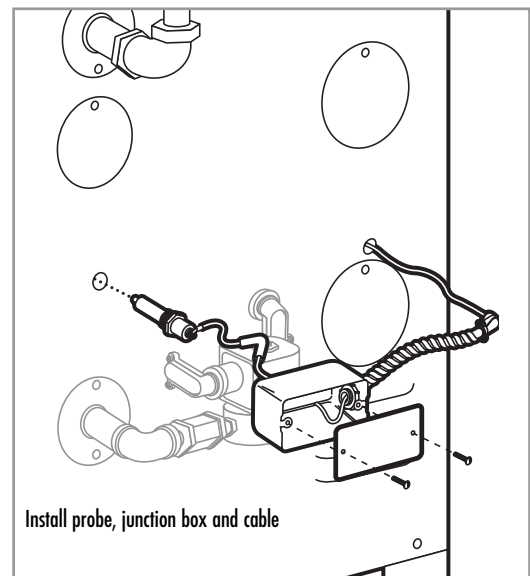
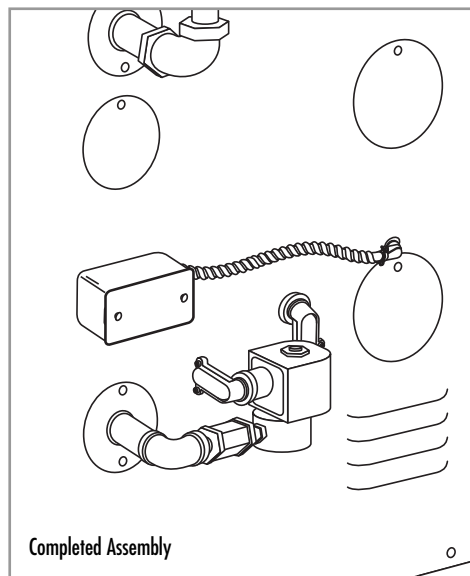
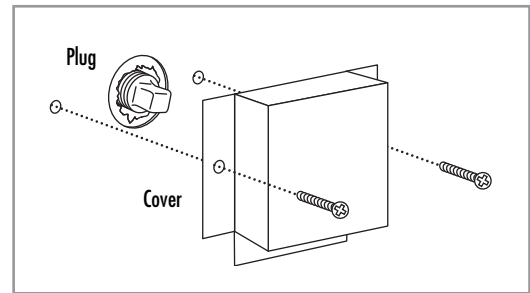
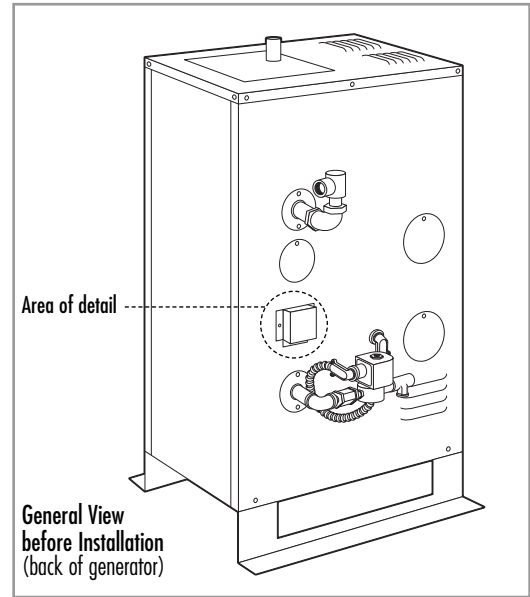

For illustrative purposes only.

Principles of Operation

MR.STEAM CU Steambath Generators require two sources of electrical supply – power voltage and control voltage. Power voltage is usually 208, 240, or 480 volt, single or three phase. Control voltage for generator suitable for operation with these voltages is 120V, 1PH.

IMPORTANT: In all cases, refer specifically to the boiler data plate located on the outside of the boiler enclosure for rated power and control voltages.

IMPORTANT: See the generator nameplate for specific electrical supply requirements for your steam generator. A lighted ON/OFF switch activates the control circuit. MR.STEAM CU Generators are equipped with automatic liquid level/low water cut-off control. CU360 – CU1400 are equipped with a dual probe type electronic control. CU2000-CU4500 are equipped with float type MM150 control (Refer to wiring diagrams.) When there is no water in the generator, the contactor is "OFF" and the water feed solenoid valve is "ON". The unit will start filling with water. When the water level has reached approximately halfway up the gauge glass, the contactor(s) will be energized and, in turn, energize the heating element(s). The water solenoid will continue to feed water for a short time and then de-energize. Steam will be available within a few minutes.

The generator has an electronic high water level cut-off control. If water level rises near the top of the pressure-vessel, the contactor(s) and the water feed solenoid valve will de-energize to "OFF".

When steam pressure reaches the operating pressure control setting, the pressure control will de-energize the contactor(s). Operating pressure control is factory set at 5 psig.

IMPORTANT: It is recommended that the steam generator not be operated higher than 5 PSIG.

Steam supply to the steambath is controlled by the F1 Plus Temperature Control System and the steam solenoid valve(s). As the room temperature selected by the owner/operator decreases below the set point, the F1Plus Control will energize the steam solenoid valve(s) and allow steam to enter the steam room. Once the set temperature on the control is reached at the sensor, the control will de-energize the steam valve, closing the valve and stopping the flow of steam into the steam room.

The F1 Plus Kit is provided with CU-HL High Limit Room Temperature Controller. CU-HL monitors the room temperature inside the commercial steambath. If the room temperature exceeds the set point, Model CU-HL shuts off the power to the CU Steambath Generator, shutting steam off. CU-HL can also send a signal to an audible alarm (provided by others).

The pressure in the generator will decrease slightly as steam leaves the generator and enters the steam room. The pressure control will energize and de-energize the contactor(s), maintaining the set pressure. As the water level in the generator decreases, the liquid level control will energize the water solenoid valve on and off and maintain proper water level.

IMPORTANT: Owners/operators should obtain a copy and familiarize themselves with the latest edition of the American College Sports Medicine Health/Fitness Faculty Standards and Guidelines, or a similar resource and reference publication, and refer to those guidelines for the proper and safe operation of a spa facility including steam rooms.

The owner/operator has the responsibility to select a room operating temperature meeting guideline requirements for steam rooms.

Important Optional Equipment

1. Optional Automatic Blowdown System (CU81600) has a 24-hour, 7-day timer that turns the steambath generator ON and OFF. At the end of the "ON" cycle, the boiler is automatically blown down, discharging daily accumulation of minerals and salts which if not drained may affect steam generator performance and operation.
2. An optional control circuit transformer provides control circuit voltage from the power supply voltage. This option is in lieu of the need for a separate control circuit.
3. An optional Auxiliary Manual Reset Low Water Cutoff serves as a back up to the standard liquid level control as required in some jurisdictions.

Automatic Blowdown Operation and Testing

 **CAUTION** To provide for safe and low temperature blowdown, and to comply with National and local plumbing and building Codes, it may be necessary to blowdown into an ASME Code blow-down separator tank, or to take other precautions to prevent damage to building drain plumbing. Consult with a licensed plumber.

 **WARNING** **Burn Hazard. Pressurized Steam and Hot Water is discharged during blowdown.**

1. Turn the override switch to permanent ON (I).
2. Turn the generator On/Off Switch to “ON”. On/Off Switch pilot light and generator should be “ON”. Motorized drain valve should be closed. Auto blowdown light should be “OFF”.
3. Turn the override switch to permanent OFF (O). On/Off Switch pilot light and generator should be “OFF”. Auto blowdown light should be “ON” Motorized drain valve remains open for approximately 10 seconds.
4. After 10 seconds: Motorized drain valve closes. Auto blowdown light should be “OFF”. On/Off Switch pilot light and generator remains “OFF”.
5. Turn the override switch to automatic (☉).

NOTE: ASME blowdown separator tank systems are available from Mr.Steam. For more informaton please contact Mr.Steam at 1-800-76 STEAM.

F1 Plus Control Operation Testing

1. Set the F1 Plus thermostat knob to 100°F. Turn “ON”the CU steam generator.
2. CU generator will heat up and produce steam in a few minutes then stop when steam room temperature reaches 100°F.
3. Slowly turn the F1 Plus thermostat knob higher. The steam solenoid valve should open and allow steam to fill the steam room again.
4. Turn the thermostat knob lower. Steam should stop.
5. Set the F1 Plus thermostat to 100°F or desired setting.

CU-HL Operation and Testing

1. Set the thermostat knob of CU-HL to max 130°F or to the temperature permitted by jurisdiction. Turn on the CU steam generator.
2. Slowly turn the thermostat knob of CU-HL lower. The CU steam generator should shut off at about the current room temperature.
3. Turn the thermostat knob of CU-HL back to max 130°F or to the temperature permitted by jurisdiction. The CU steam generator should turn back on. NOTE: The operating room temperature setting is determined by the owner/operator of the facility. For guidance, refer to ASCM guidelines or equal reference.

NOTE: The operating room temperature setting is determined by the owner/operator of the facility. For guidance, refer to ASCM guidelines or equal reference.

Warning Signage

The CU Steambath generator is provided with a WARNING sign. This WARNING is to be secured to the outside of the steam room, on the steamroom door or adjacent to that door. It's location must be such that all steam bathers are readily made aware of the important information contained in the sign.



Pre-Operation Check

Low water Cutoff (LWCO) and Feed Control Operation and Testing

1. All valves for incoming water supply are to be fully opened. Main disconnect switch to be in "ON" position. Generator switch to be in "ON" position. Since generator will be empty, water solenoid will be energized allowing the generator to fill with water until proper level is reached. Then the contactors will energize and supply voltage to heating elements.
2. Water level control operation: At this point the water should be visible approximately half way up the sight glass. Slowly open the drain valve located at bottom of the generator. The water level will fall allowing the low water cutoff/water level control to energize the feed water system. Close the drain valve for proper operation.
3. Low water cut-out switch performance. Close water feed valve. Open the drain valve completely. Maintain this condition until the water level falls within the gauge glass enough to cause the low water cutout switch to de-energize the heating elements. All contactors will be in the de-energized state at this time. Close the drain valve. For automatic re-setting type low water cutoff switches, feed system will return the water level to normal. For manual re-set the reset button must be depressed to complete circuit. The generator is now qualified for proper low water cutout and normal liquid-level operating conditions.

NOTE: For automatic blowdown, turn timer off and on until water level is low enough to de-energize heaters.

Pressure Controls Operation and Testing

Steambath generators are provided with one hi-limit pressure control and at least one operating pressure control.

1. All pressure controls are equipped with a screw allowing for setting of the desired operational and hi-limit pressures.
2. It is recommended that the hi-limit control be set at 8–10 psig maximum and the operating pressure control(s) shall not be set above 5 psig.

Note: Models CU360 - CU3000 are provided with one (1) automatic reset operating pressure control and one (1) manual reset high limit pressure control. Models CU 4500 is provided with two (2) automatic reset operating pressure controls and one (1) manual reset high limit pressure control.

3. **Pressure control operation check:** Manually close the steam outlet valve. Switch the generator on to allow for steam pressure build-up. Pressure gauge reading will build and the operating pressure control will shut off the generator at the pressure setting. Re-setting the operating pressure control is accomplished by manually bleeding off pressure through the steam outlet valve and allowing the pressure to drop below the desired set point.

Torque Values

Check to insure all element flange bolts, element terminals, and contactor terminals are tightened to the following specifications.

IMPORTANT: See page 30 for additional information and illustrations.

TORQUE VALUES	
Element Flange Bolts	22 lb-ft
Element Terminals	20 lb-in
Contactor Terminals	50 amp 25 lb-in
	60 amp 45 lb-in
	75 amp 75 lb-in

Operation

 **CAUTION** With all power disconnected at main switch, insure all electrical and mechanical connections are tight before energizing unit to prevent electrical problems and mechanical leaks.

1. Turn on water and electrical supply, power and control voltage suppliers. Turn unit switch to ON position; Switch light will go ON and water level will reach operating level automatically.
2. When proper operating level is reached (approximately half way up the gauge glass), the heating element(s) will be energized. In approximately 20 minutes, steam will begin to be produced.
3. Adjust the F1 Plus operating temperature control to the desired steam room setting at the sensor (range 100°F – 120°F). Operating temperature is at the discretion of the owner/operator.

 **CAUTION** For user comfort, the F1 Plus operating control is provided with an adjustable temperature range. The F1 Plus control will cycle automatically to maintain the room operating temperature selected by the owner/operator at the sensor at the set point temperature.

4. If not supplied with an automatic blowdown system, the generator must be blown manually down daily in accordance with manual blowdown instructions below. An optional automatic blow-down assembly is recommended for daily maintenance.

Manual Blowdown Instructions

Blowdown is an essential part of operation. It is an excellent preventative maintenance procedure and will prolong steambath generator operation. Insure the following recommended blowdown schedule is established and followed daily:

1. If blowdown is conducted manually, at the end of each working day while unit is still operating, turn ON/OFF switch to the "OFF" position and close water supply valve. De-energize wall-mounted safety switch. Open blowdown valve(s) SLOWLY. **IMPORTANT: Pressure may still be in the generator.**
2. Discharge is complete when gauge glass shows no water. Unit has been effectively drained. Follow this procedure:
 - a. Fully close the blowdown valve
 - b. Fully open water supply
 - c. Put ON/OFF switch in the "ON" position
 - d. Close wall-mounted safety switch
3. When re-filling is complete (water feed solenoid valve de-energizes and water is visible to half-way level in gauge glass), turn off generator unless further operation is required.
4. If you have been supplied with a manual reset low water control, as required by some states, the reset button on the control must be reset before unit will begin developing pressure. Do not push reset until unit has filled with water.
5. More frequent blowdowns may be required in area with hard water or excessive usage. Please consult with factory.

 **CAUTION** To provide for safe and low temperature blowdown, and to comply with National and local plumbing and building Codes, it may be necessary to blowdown into an ASME Code blow-down separator tank, or to take other precautions to prevent damage to building drain plumbing. Consult with a licensed plumber.

NOTE: ASME blowdown separator tank systems are available from Mr.Steam. For more informaton please contact Mr.Steam at 1-800-76 STEAM.

Automatic Blowdown Instructions

Automatic Blowdown Systems drain the steambath generator every 24 hours (or more often if required or desired). It also turns the generator "ON" and "OFF". Blowdown occurs after the timer turns the generator off. The blowdown pilot light is energized during blowdown. To set the timer, refer to instructions on inside of element access door.

 **CAUTION** Use of chemical cleaning compounds voids warranty.

 **CAUTION** To provide for safe and low temperature blowdown, and to comply with National and local plumbing and building Codes, it may be necessary to blowdown into an ASME Code blow-down separator tank, or to take other precautions to prevent damage to building drain plumbing. Consult with a licensed plumber.

NOTE: ASME blowdown separator tank systems are available from Mr.Steam. For more informaton please contact Mr.Steam at 1-800-76 STEAM.

Maintenance Instructions

To establish a good preventive maintenance program, we suggest that the site equipment foreman, engineer or owner/operator familiarize themselves with these guidelines:

1. **Daily blowdown** at max 5 PSIG operating pressure is recommended for best steambath generator performance. In order to safeguard the heating element(s) within the steambath generator, the main wall switch and the steambath generator switch shall both be placed in the OFF position **prior to blowing down the generator**. Blowdown instruction should then be followed as outlined in this manual. **DO NOT** use chemical cleaning compounds in the steambath generator since the chemical agents may damage some of the generator components. A daily blowdown will assist in prolonging product operation.
2. **Only after electric power supplies have been disconnected at main disconnect switch, a monthly inspection** should be made of all wiring. All electrical connections should be checked for tightness. A check for steam and/or water leaks should be made and any loose fittings must be tightened immediately. Check heating element flange bolts for tightness. Specific torque in 22 Ft. lbs. cold.
3. **In hard water areas**, generators equipped with the McDonnell-Miller control (Models CU-2000 and larger), should be checked for proper operation **every four months or sooner**. At the same time, a bottom heating element should be removed and inspected. If scale has begun to form, all elements should be cleaned and re-installed, using only new gaskets and bolts. The pressure control should also be removed to insure that the bellows has not become clogged. (See trouble-shooting guide for instructions.) Check valves should be inspected for leakage and proper operation.
4. Generators equipped with level probes (Models CU 2000 - CU 1400) for maintaining operating water level and probe for auxiliary low water cut-off protection need special consideration. In hard water areas, the probe should be checked for chemical deposits and cleaned if necessary. This should be done **every four months or sooner**. See the trouble-shooting manual for instructions.

CAUTION Under any circumstances, only qualified service personnel should attempt the above procedures. Always insure all electrical power supplies are disconnected at the main disconnect switches to prevent electric shock. Always insure that pressure within steam generator is 0 PSIG (zero pressure) whenever plumbing connections, including any factory-plumbed components, are being disconnected.

5. **Torque Values** Every two months or more frequently if required, insure all element flange bolts, element terminals, and contactor terminals are tightened to the following specifications.

TORQUE VALUES		
Element Flange Bolts	22 lb-ft	
Element Terminals	20 lb-in	
Contactor Terminals	50 amp	25 lb-in
	60 amp	45 lb-in
	75 amp	75 lb-in

IMPORTANT: See page 30 for additional information and illustrations.

24-Hour and 7-day Time Switches



PROGRAMMING

For CU steam bath generators equipped with Automatic Blowdown Systems CU 81500 and CU 81600, refer to the following instructions for time clock operation and settings. Timer settings for blowdown operation are at the discretion of the owner/operator.

The weekly program dial shows the seven days of the week and AM/PM imprints for each day.

The time switch is set by pushing the captive trippers to the outer ring position for the entire period that the load is to be turned ON, i.e., 2 hours to each tripper on the 7-day dial. When the tripper is pushed to the inside, the switch is in the OFF position.

SETTING TIME

**To set the current time and day of week, turn the minute hand clockwise
Do not set the time by rotating "Outer" Dial.**

Turn the minute hand clockwise until the day of the week and the time of day on the outer dial is aligned with the triangle marker on the inner dial (two o'clock).

Example for 7-day program dial Monday 10:30 AM. Turn the minute hand clockwise until Monday 10:30 AM is aligned with the triangle on the inner dial. The hour and minute hand will show exactly 10:30.

FOR MANUAL OVERRIDE

Manual override can be accomplished at the discretion of the owner/operator as follows.

3-WAY MANUAL OVERRIDE SWITCH

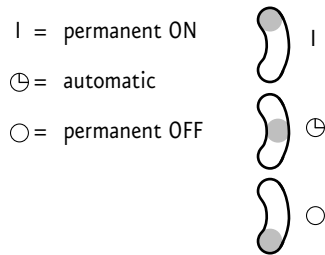

IMPORTANT: It is recommended that for periodic and effective blowdown, the override switch be set in the ⊕ automatic setting.

Water Gauge & Gauge Glass Installation

IMPORTANT: Only properly trained personnel should install and maintain water gauge glass and connections. Pressure in generator must be at zero before proceeding. Remember to wear safety gloves and glasses during installation. Before installing, make sure all parts are free of chips and debris.

1. Apply Teflon tape or pipe dope to pipe threads. Install top gauge fitting (fitting without a drain valve) into the upper most tapping. Wrench tighten the fitting until it is snug and the glass outlet is pointing at five o'clock (about 1/8 turn from its final downward vertical position).
2. Install the bottom gauge fitting (the fitting with a drain valve) until it is snug and the glass outlet is pointing directly upward. Verify top and bottom fittings are threaded into the tapping the same number of turns (distance A = distance B).
3. Remove glass packing nut, friction washer (or packing gland, depending upon the model), and glass packing from the fittings, and place them, in the same order, on to both ends of the gauge glass. Push both packings about an inch up the gauge glass.
4. Gently insert one end of the glass into the top gauge fitting. Keeping the glass inside the top fitting, gently rotate the top gauge fitting clockwise until vertically aligned with the bottom gauge, then insert glass into bottom fitting until glass bottoms out on the shoulder inside the bottom fitting.
5. Carefully raise glass about 1/16" and slide lower glass packing down until the glass packing contacts the lower gauge fitting. DO NOT allow the glass to remain in contact with any metal!
6. Carefully slide upper glass packing up as far as possible.
7. Hand tighten both glass packing nuts, then tighten 1/2 turn more by wrench. Tighten only enough to prevent leakage. DO NOT OVERTIGHTEN! If any leakage should occur, tighten slightly, a quarter turn at a time, checking for leakage after each turn.

IMPORTANT: Read all warnings and instructions before performing installation or maintenance.

WARNING Safety glasses and gloves should be worn at all times when working with or examining water gauge glass and connections.

Pressure in generator to be at zero before proceeding.
 Improper installation or maintenance of gauge glass and connections can cause immediate or delayed breakage resulting in bodily injury and/or property damage.

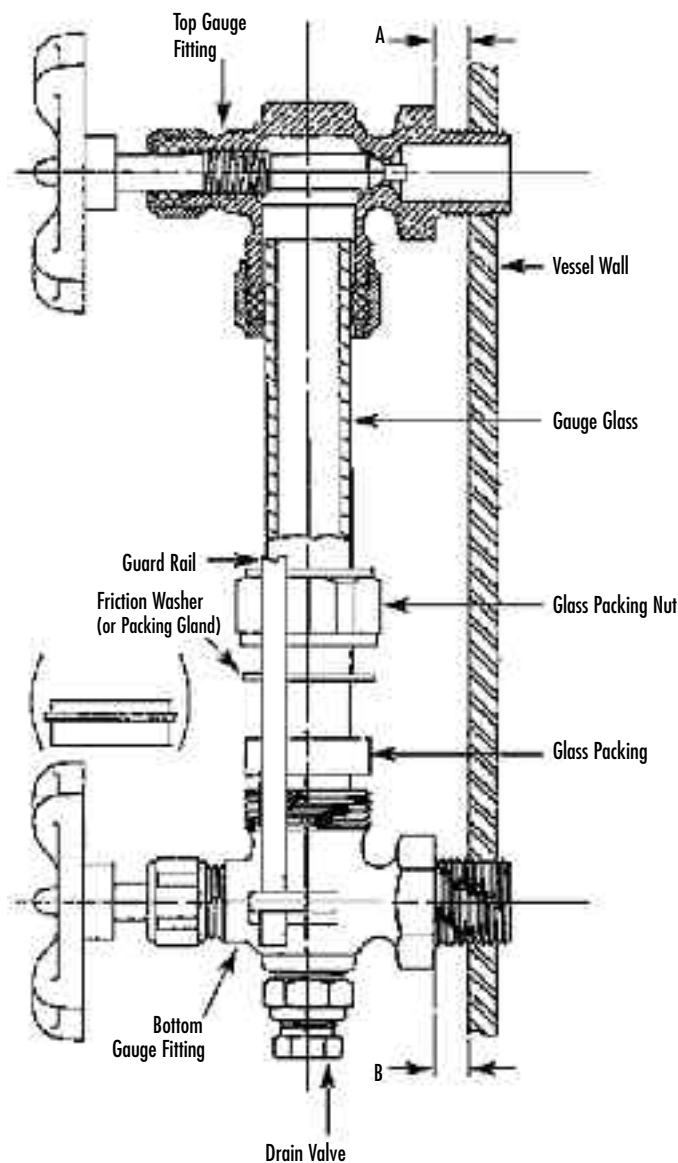

Use and Care

DO NOTs

- DO NOT use glass if it contains any scratches, chips, or any other visible signs of damage.
- DO NOT reuse any tubular glass or glass packings.
- DO NOT subject gauge glass to bending or torsional stresses.
- DO NOT over tighten glass packing nuts.
- DO NOT allow glass to touch any metal parts.
- DO NOT exceed the recommended pressure of the gauge or gauge glass.
- DO NOT clean the gauge or gauge glass while pressurized or in operation.

DO's

- DO verify proper gauge has been supplied.
- DO examine gauge glass and packings carefully for damage before installation.
- DO install protective guards and utilize automatic ball checks where necessary to help prevent injury in case of glass breakage.
- DO inspect the gauge glass daily, keep maintenance records, and conduct routine replacements.
- DO protect glass from sudden changes in temperatures such as drafts, water spray, etc.

MAINTENANCE

Examine the gauge regularly for any signs of clouding, scratching, erosion, or corrosion. The glass should be inspected daily until the need for replacement becomes apparent. This will help establish the routine inspection and routine replacement schedules.

CLEANING

Use commercial non-abrasive glass cleaners to keep glass clean. Use diluted acids such as Hydrochloric (muriatic) acid when regular cleaners do not seem to work. Do not use wire brushes or any other abrasive materials which could scratch the glass.

INSPECTION

Examine the surface of the glass for scratches, corrosion, chips, cracks, surface flaws, or nicks. To do this, shine a very bright concentrated light at an angle of about 45 degrees. A defective glass will glisten as the light strikes imperfections. Glass which appears cloudy or roughened, and will not respond to cleaning, should be replaced.

STORING

Keeping gauge glass in original packaging until ready to install.

Trouble Shooting

 **CAUTION** To prevent risk of electric shock, trouble shooting should be done only by a qualified licensed electrician

Problem	Probable Cause	Suggested Remedy
No water in generator	Water supply is "OFF"	Turn on water supply
	Clogged strainer	Clean or replace strainer screen
	Control voltage disconnected	Restore control voltage
	Defective ON/OFF control switch	Check/replace control switch
	Defective water solenoid valve	Check/replace water solenoid valve
	Defective PC Board	Check/replace PC Board
	Water feed probe not functioning	Check/replace water feed probe (Models 360-1400) and probe isolator and/or MM150 (Models CU2000 & higher)
	Clogged isolator tube	Check/replace isolator tube (models 360-1400)
Generator does not heat	Power supply disconnected	Restore power supply
	No water in generator	See above
	Hi-Limit pressure control tripped	Clean out syphon tube & reset pressure control
	WCO not functioning	Check/replace LWCO probe
	Defective contactor	Check/replace contactor
	Defective pressure control	Check/replace control switch
	Defective PC Board	Check/replace PC Board
	Defective heating element	Check/replace heating element
Contactor chatters	Defective Hi-water PC board	Check/replace Hi-water PC Board
Generator floods	Water feed solenoid installed backwards	Reverse solenoid connection "A" towards generator CU 360-1400 1" towards generator 2" towards water supply
	Defective water solenoid valve	Check/replace water solenoid valve
	Defective PC Board	Check/replace board
	Water feed probe (Models 360-1400) not functioning	Check/replace water feed probe and isolator
	Clogged isolator tube	Check/replace isolator tube (models 360-1400)
	MM 150 (Models CU 2000 and higher) is clogged	Clean out pipes under MM 150 Equalizing piping and float chamber
CU81600 rotates twice	Jumper in (X) BRN & BLK terminals not removed	Check/remove jumper (page 18)

Check

PC Board - Models CU 360, CU 500, CU 750, CU 1000, CU 1400

1. Turn the control voltage "ON" and measure the voltage across "L1" and "L2". The voltage should be approximately 110 VAC.
2. On the water feed control, disconnect the wire from the "H" terminal and check the voltage across "L2" and "FILL". The voltage should be approximately 110 volts (same as "L1" and "L2"). Connect a jumper between the "H" and "C" terminals. The voltage between "L2" and "FILL" should be zero.
3. On the LWCO (heat control), disconnect the wire from the "L" terminal. There should be no voltage between the "L2" and "HTR" terminals. Connect the jumper between the "L" and "C" terminals. The voltage between "L2" and "HTR" should be 110V.

Low Water Cutout, Water Feed and High Water Cutout Probes

Models CU-360 through CU-1400 are equipped with two probes for low water cut-off (LWCO) and water feed control. Failure to clean the probes may result in generator not operating, overflow or element failure.

 **CAUTION** Turn off all power supplies to steam bath generator and release pressure to zero (0 psig) before removing probes.

1. Probes are located in the top of the generator. Remove covers and disconnect wires from probes. Note wire connections.
2. Remove probes using a standard spark plug wrench. Care should be taken not to damage the insulation.
3. Check probes for deposits. Use emery cloth to clean probes.
4. Remove and flush probe isolator (thoroughly) with water. If clogged, use a long piece of wire to remove obstruction. Replace if necessary, center probe rod in isolator tube.
5. Use teflon tape on probe threads and reinstall.
6. After installation, make sure probe is not touching ground. With generator drained and probe wires disconnected, there should be no resistance (X) between probe and ground. Check for leaks.

Steam Solenoid Valve

1. Check voltage rating of solenoid valve (120 VAC for United States, Canada, Mexico; may be 220-240 VAC for other countries).
2. Check voltage across solenoid coil.
 - a. If there is voltage across coil and valve does not allow passage of steam, check for clogged valve. Clean outline with bottle brush. If solenoid valve is still malfunctioning, the valve is defective and should be replaced.
 - b. If there is no voltage across coil, check room temperature control.

F1 Plus Control and Sensor: Consult Factory

Heating Element

IMPORTANT: Turn off all power at circuit breaker. Consult factory for resistance values.

1. Check power voltage across heating element terminals. Refer to nameplate data for voltage rating. Voltage should be as marked on nameplate.
2. Using an ammeter, measure total current draw as per nameplate rating. (See also Amperage Chart, page 8) Each leg should register about the same current reading.
3. If there is more than one heating element, check amperes of each element. Each leg of the same element should register about the same reading for that element. Reading may be different from other elements due to KW (Kilowatt) rating of individual heating element.
4. Check heating element for resistance values. Consult factory for the resistance values for the element specifications.

 **CAUTION** Prior to checking boiler disconnect boiler from electric power supply at main safety switch or fuse panel. Turn boiler switch to OFF.

Instructions for Element Replacement

READ INSTRUCTIONS COMPLETELY BEFORE STARTING WORK

CAUTION Before installing your new elements be sure McDonnell Miller low water cut-off and aux. low water cutoff (if supplied) is operating properly. The float chamber and lower equalizer column of the MM control must be completely clear of sludge or other foreign matter. Failure to do this may cause the immediate burn-out of the new elements. If the unit is probe equipped, check condition of the probes and isolator.

All elements are thoroughly checked before shipment. The manufacturer cannot be responsible for burn-outs caused by a faulty low water cut-off.

The lower equalizer column can best be examined by breaking the unions on either side and then visually and manually examining the piping with your finger or probes to see if it is clear and clean.

IMPORTANT: Models CU 360 - CU 1400 use probes for liquid level sensing and control. Model CU 2000 and higher use McDonnell-Miller MM 150.

1. Disconnect boiler from electric power supply at main safety switch or fuse panel. Then turn boiler switch to "OFF" position.
2. Close water supply valve on incoming water supply line. Drain boiler completely of water.
3. Open boiler door to access heating element.
4. Disconnect wire (electric) leads connecting element to main power system of boiler. Again, note wire connections to facilitate re-assembly. Proceed to remove and discard (6) bolts from flange.

IMPORTANT: Note the wire connections to facilitate re-assembly (see wiring schematic). Remove and discard six (5/16"-18) bolts from flange. Do not reuse these bolts.

5. Thoroughly clean boiler flange of all foreign material. Be certain no part of old gasket remains on flange.
6. Apply "Slic-Tite" Gasket Compound (or equal) to both surfaces of new gasket supplied with replacement element. Proceed to install element flange assembly with gasket between boiler flange and element flange. In doing this, be careful to align flange holes so element wire connection terminals on element assembly are in line with previously disconnected wire leads to facilitate easy connections.

NOTE: Observe markings on element flange. Install element marking "TOP" on top.

7. Use only new element flange bolts. Tighten all (6) element flange bolts to a torque value of 22 lb-ft each (see illustration).
8. Connect all wires to the terminals. Tighten all element terminals to a torque value of 20 lb-in each (see illustration). Make sure all wires are clean and bright to assure good electrical contact.
9. Check that the wires are correctly connected to the contactor terminals and are tightened to a torque value of 45 lb-in. (see illustration). Make sure all wires are clean and bright to assure good electrical contact.
10. Open water valve to allow water supply to reach boiler feed mechanism.
11. As boiler automatically refills, observe the new flange assembly for possible leaks. If water is noticed, the bolts must be re-tightened. Before doing this, turn the boiler off at the main fuse safety switch.
12. When boiler reaches working pressure, check flange assembly again for leaks.

CAUTION Avoid use of chemical cleaning compounds. Follow maintenance instructions provided with the boiler.

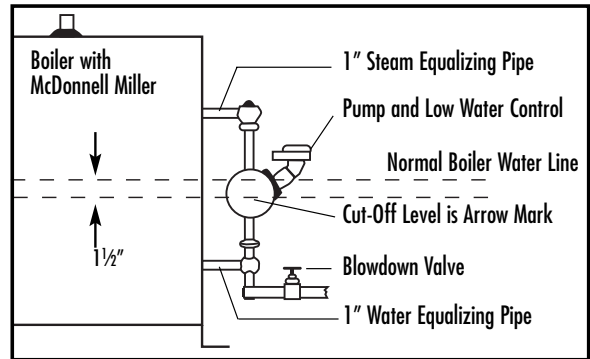

Torque Values:

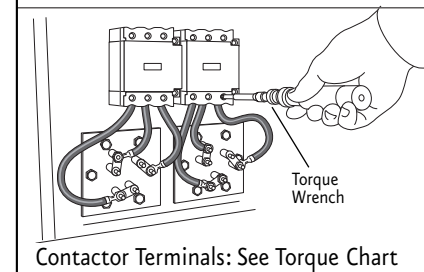
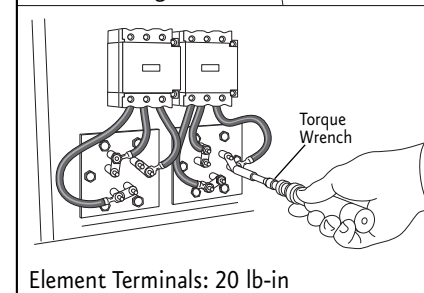
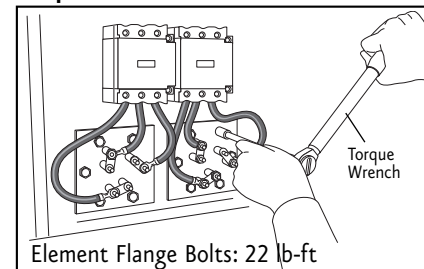

For Illustrative Purposes Only.
Power wiring shown in approximate factory-installed location

TORQUE VALUES	
Element Flange Bolts	22 lb-ft
Element Terminals	20 lb-in
Contactor Terminals	50 amp
	60 amp
	75 amp

CU 360-CU 1400 Typical Component Arrangement

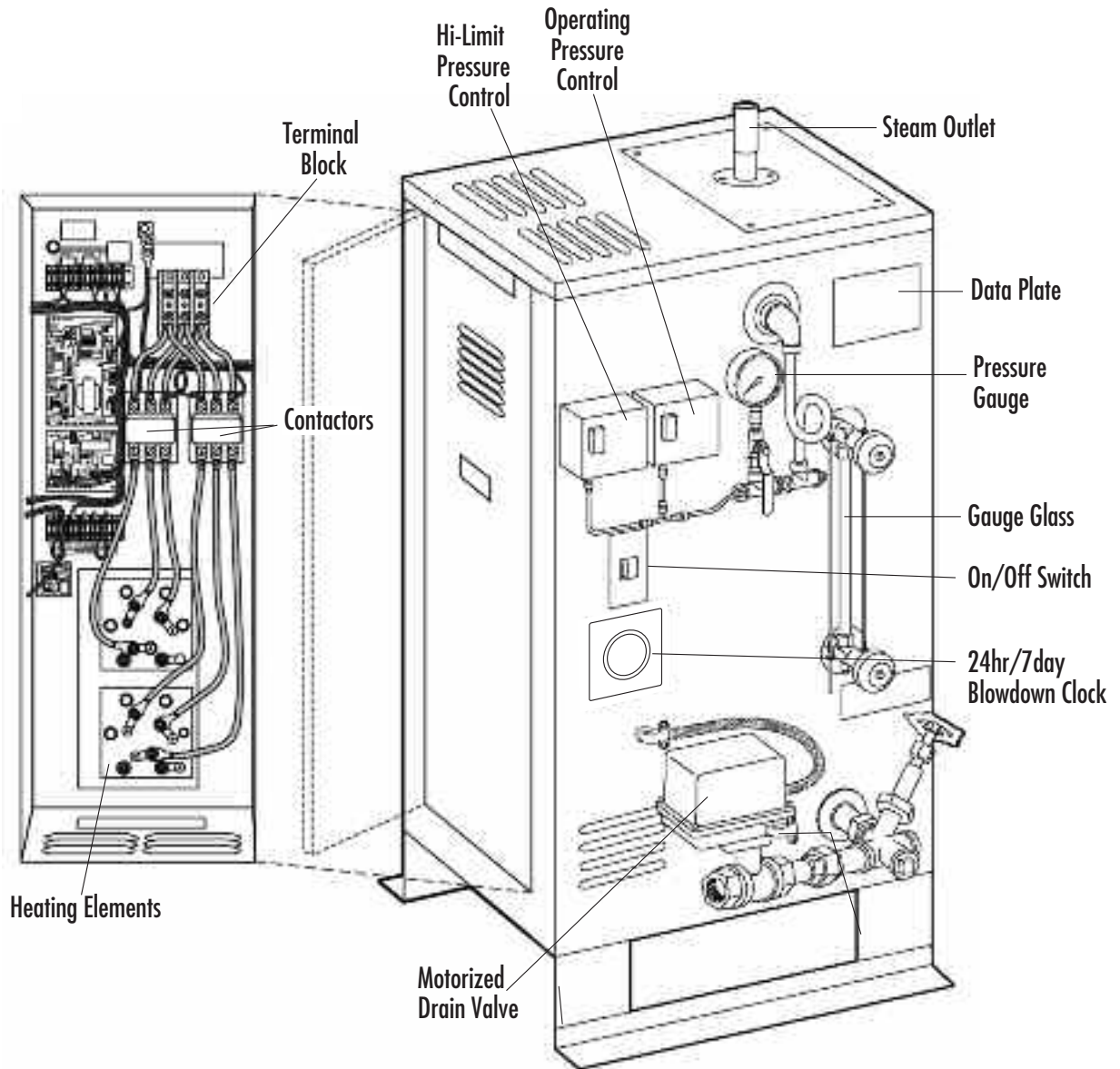

For Illustrative Purposes Only.

CU 2000-4500 with FI Plus, Clock and Blowdown

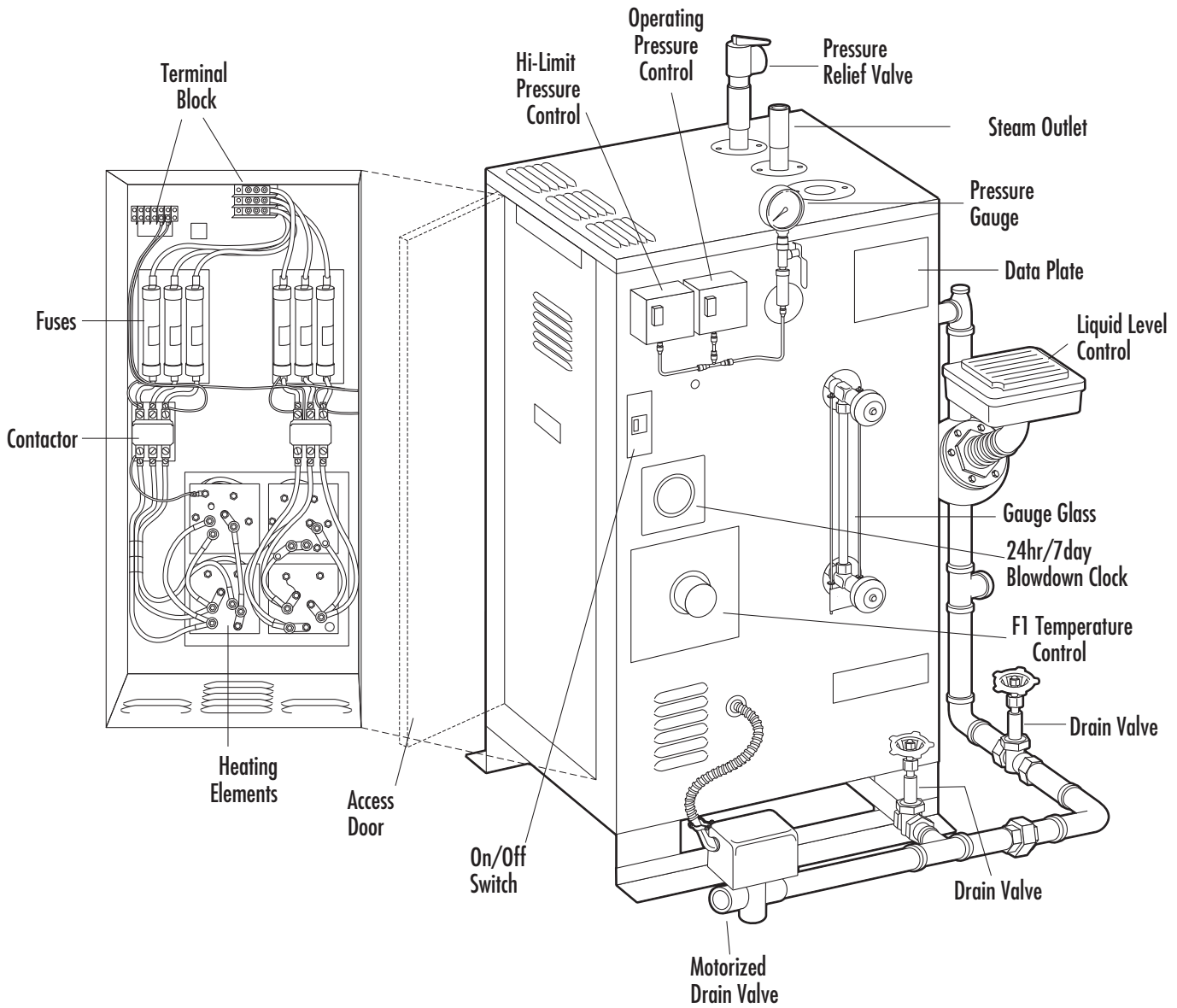

For Illustrative Purposes Only.

Commercial Steambath Replacement Parts Models CU 360 – CU 4500

PART #	DESCRIPTION
BLOWDOWN	
99353	TIME DELAY RELAY BOARD
102470	BLOWDOWN VALVE V FOR CU81500-SOFT WATER
103661	BLOWDOWN VALVE V FOR CU81600-HEAVY DUTY
103805	MIL 72* BLOWDOWN TIMER
103662	Digi 20* BLOWDOWN TIMER
CONTACTORS	
99003	50A 3 POLE 120V 50/60
99006B	50A 4 POLE 120V 50/60
99075	60A 3 POLE 120V 50/60
102206-1	75A 3 POLE 120V 50/60
CONTROLS	
103730	F1 PLUS BOARD 120V
103730C	F1 PLUS BOARD 240V
103731-1	SENSOR ONLY FOR F1 PLUS WITH GUARD + 25' CABLE
CU-99204ELKA	F1 PLUS FIELD KIT 120V (with SENSOR + BOARD, GUARD, CABLE)
CU-99204ELKC	F1 PLUS FIELD KIT 240V (WITH SENSOR + BOARD, GUARD, CABLE)
CU-99216B	CU-30 MINUTE MECHANICAL TIMER
CU-HL	Hi-Limit Room Temperature Control
CU-99216DIG	DIGITAL TIMER
ELECTRIC	
90229	PROBE SPARK PLUG-(1) FOR EACH ROD
92830	ON/OFF SWITCH
99207	TERMINAL BLOCK 150 AMP 3 POLE
99524-6T	18" #6 WIRE WITH TERMINAL-FOR HEATING ELEMENT
99807B	1/4" x 9" PROBE ROD STAINLESS** CU360 - CU750-LOW WATER
99807C	1/4" x 6" PROBE ROD STAINLESS** CU360 - CU750-HI WATER
103127	DUAL PROBE LL PC BOARD 20V CU360-CU750
103127-1	DUAL PROBE LL PC BOARD 240V CU360-CU750
100378	PROBE ISOLATOR
90229-1	AUX LWCO probe assembly
90241MR	Aux LWCO Board
90241N	Aux HWCO Board
92829	Aux LWCO Pilot Light

ELECTRIC (cont.)

99348	AUX LWCO RESET BUTTON
99315	FUSE BLOCK 208/240V
99314	POWER FUSES 208/240V 60A 250V
99317	FUSE BLOCK 480V
99316	POWER FUSES 480V 60A 600V
CU99331B	CONTROL VOLTAGE TRANSFORMER 208V to 120V
CU99331C	CONTROL VOLTAGE TRANSFORMER 240V to 120V
CU99331F	CONTROL VOLTAGE TRANSFORMER 480V to 120V
99580	TERMINAL BLOCK 4 POLE
99593	TERMINAL BLOCK

ELEMENTS

39121B	12 KW 208V 1PH
39121C	12 KW 240V 1PH
39123B	12 KW 208V 3PH
39123C	12 KW 240V 3PH
39123F	12 KW 480V 3PH
39181B	18 KW 208V 1PH
39181C	18 KW 240V 1PH
39183B	18 KW 208V 3PH
39183C	18 KW 240V 3PH
39183F	18KW480V3PH
99088	GASKET COMPOUND
99096	GASKET 4 1/2" DIA.
103540	GASKET KIT (includes gasket, hardware & bolts)

GAUGE GLASS

99074-1	GAUGE GLASS with 2 GASKETS (CU360 - 750) GAUGE GLASS with 2 GASKETS (CU1000 -1400) (SN beginning with "AX")
99080-1	GAUGE GLASS with 2 GASKETS (CU1000 - CU1400) (SN beginning with "N") GAUGE GLASS WITH 2 GASKETS (CU2000 - CU3000)
99081-1	GAUGE GLASS with 2 GASKETS (CU4500)
99174CV	GAUGE GLASS o-RING GASKET-VITON WASHER
99173C	GAUGE GLASS VALVE SET LESS TUBE AND RODS

MECHANICAL FEEDER

99114	MECHANICAL LOW WATER CUTOFF & FEEDER (mm 150)
99120	2 WIRE MERCURY SWITCH
99121	3 WIRE MERCURY SWITCH
103914	MICRO SWITCH ASSY
SA150-14	HEAD GASKET
SA150-106R	BELLOWS ASSEMBLY w/GASKET
SA150-11	FLOAT ROD & BALL ASSEMBLY

*Both MIL 72 and DIGI 20 BLOWDOWN TIMERS are available for surface mounting. Add suffix "K" to Part Number

**Also CU1000 -1400 w/SN beginning with "AX"

Commercial Steambath Replacement Parts **Models CU 360 – CU 4500**

PART #	DESCRIPTION
WATER FEED & STEAM SOLENOIDS	
99031	1/2" 120V CU1000-CU1400 (SN beginning with "N") CU2000-CU4500 (all)
99032	1/2" 240V CU1000-1400 (SN beginning with "N") CU2000-CU4500 (all)
99042	1/4" 120V CU360-CU1400 (SN beginning with "AX") CU360-CU750 (SN beginning with "DP")
99042C	1/4" 240V CU360-CU1400 (SN beginning with "AX") CU360-CU750 (SN beginning with "DP")
99284A	LOW PRESSURE STEAM 120V 1"
99285A	LOW PRESSURE STEAM 120V 1/2"
99284B	LOW PRESSURE STEAM 240V 1"
99285B	LOW PRESSURE STEAM 240V 1/2"
99286A	LOW PRESSURE Steam 120V 3/4" CU 360-1400 (SN beginning AX 3197) CU 2000-4500 (SN beginning N4-18455)
PRESSURE CONTROL	
99113R	OPERATING PRESSURE CONTROL 0-15 PSIG
99290	PRESSURE GAUGE 0-30 PS
99969R	HI-LIMIT CONTROL W/MANUAL RESET 15PSIG
FB023	PIGTAIL 1/4" NPT 180°
VALVES	
99123	STRAINER 1/2 INCH
99162	SPRING CHECK VALVE 3/8" CU1000-1400 (SN beginning with "N") CU2000-CU4500 (all)
99167	SPRING CHECK VALVE 1/2" CU360-CU1400 (SN beginning with "AX") CU360-CU750 (SN beginning with "DP")
99178	VALVE 1/2 STEAM BALL
99182	VALVE GATE VALVE 3/4 STEAM
99184	VALVE GATE VALVE 1 STEAM
99297	15 PSIG SAFETY VALVE 3/4"
MISC. PARTS	
CU-99212PC	STEAM HEAD - 1/2" POLISHED CHROME
103984PC	STEAM HEAD - 3/4" POLISHED CHROME
103985	ACRYLIC SHIELD
CU-99216B	30 MINUTE MECHANICAL TIMER
CU-99216DIG	30 MINUTE DIGITAL COUNTDOWN TIMER